

# North West Wales Dendrochronology Project Plas Tirion, Llanwrst, Conwy



**EAS Client Report 2012/10  
November 2012**

**Engineering Archaeological Services Ltd  
Unit 2 Glanypwll Workshops  
Ffordd Tanygrisiau  
Blaenau Ffestiniog  
Gwynedd  
LL41 3NW**

**Registered in England N<sup>o</sup> 286978**

**A Report Commissioned by the North-West Wales Dendrochronology Project in  
Partnership with The Royal Commission on the Ancient and Historical Monuments of  
Wales**



# **North West Wales Dendrochronology Project Plas Tirion, Llanwrst, Conwy**

**EAS Client Report 2012/10**

**Commissioned by  
Margaret Dunn  
for  
North West Wales Dendrochronology Project**

**November 2012**

**By  
I.P. Brooks**

**Engineering Archaeological Services Ltd  
Unit 2 Glanypwll Workshops  
Ffordd Tanygrisiau  
Blaenau Ffestiniog  
Gwynedd  
LL41 3NW**

**Registered in England N° 286978**



# Content

**Grid Reference**

**NPRN Number**

**Status**

**Introduction**

**Methodology**

**Survey Report**

**Dendrochronology Sampling**

**Conclusions**

**Acknowledgements**

**References**

**Appendix 1: Sources**

## List of Figures

**Figure 1: Location**

**Figure 2: Extract of the First Edition Ordnance Survey Denbighshire XVI  
Map**

**Figure 3: Ground Floor Plan**

**Figure 4: First Floor Plan**

**Figure 5: Attic Plan**

**Figure 6: Door between the kitchen and the lower hall**

**Figure 7: Blocked Cupboard**

**Figure 8: Blocked Window**

**Figure 9: Mullions**

**Figure 10: First Floor Partition**

**Figure 11: Trusses 1 and 2**

**Figure 12: Trusses 3 and 4**

## List of Plates

**Plate 1: Front elevation (2011)**

**Plate 2: Window in the northern face of the southern range**

**Plate 3: Blocked doorway in the northern elevation of the southern range**

**Plate 4: The porch**  
**Plate 5: The southern elevation**  
**Plate 6: The porch on the southern elevation**  
**Plate 7: The relationship between the southern porch and the stone stairs**  
**Plate 8: The roof of the southern porch**  
**Plate 9: Blocked window in eastern gable end of the southern range**  
**Plate 10: Detail of the window frame in the blocked window in the gable end of the southern range**  
**Plate 11: The stair tower**  
**Plate 12: The northern end of the rear elevation of the main range**  
**Plate 13: The northern gable end**  
**Plate 14: The kitchen fireplace before restoration**  
**Plate 15: The kitchen fireplace after the removal of the later structures**  
**Plate 16: Wooden hook on the mantle shelf above the kitchen fireplace**  
**Plate 17: The screen adjacent to the kitchen fireplace.**  
**Plate 18: Small widow in the north western corner of the kitchen**  
**Plate 19: Remains of a cupboard cut by the doorway between the kitchen and the hall**  
**Plate 20: Original doorway between the kitchen and the hall**  
**Plate 21: Detail of the ovolo moulding of the doorway between the kitchen and the hall**  
**Plate 22: The hall fireplace before restoration**  
**Plate 23: Plaster overmantle in the ground floor hall**  
**Plate 24: Remains of the plaster moulding around the ground floor hall fireplace**  
**Plate 25: The overmantle in the parlour**  
**Plate 26: The cupboard in the parlour**  
**Plate 27: Cupboard doors in the parlour**  
**Plate 28: Detail of the hinge to the cupboard of in the parlour**  
**Plate 29: Block fireplace in Room 1**  
**Plate 30: Plaster overmantle in Room 3**  
**Plate 31: Detail of the overmantle in Room 3**  
**Plate 32: Details of figures on the overmantle in Room 3**  
**Plate 33: Details of figures on the overmantle in Room 3**  
**Plate 34: The partition between Rooms 3 and 4 and 5**  
**Plate 35: Western doorhead in the partition between Room 3 and Rooms 4 and 5**  
**Plate 36: Eastern doorhead in the partition between Room 3 and Rooms 4 and 5**  
**Plate 37: The partition between Room 3 and the first floor corridor**  
**Plate 38: Turned spindles in the partition between Room 3 and the corridor**  
**Plate 39: Swelling on the ceiling beam in Room 3**  
**Plate 40: Blocked first floor window**  
**Plate 41: Overmantle in Room 4**  
**Plate 42: Mock post and panel partition in Room 4**  
**Plate 43: The overmantle in Room 5**

**Plate 44: Ovolo moulded mullion in Room 5**  
**Plate 45: Timber framing in the stair tower**  
**Plate 46: Timber framing in the stair tower**  
**Plate 47: Timber framing in the stair tower**  
**Plate 48: Truss 1**  
**Plate 49: Dowel holes below Truss 1**  
**Plate 50: Dowel holes for mortice below Truss 1**  
**Plate 51: Scratch marks on Truss 2**  
**Plate 52: Truss 3**  
**Plate 53: Door head below Truss 3**  
**Plate 54: Secondary principal rafters, Truss 3**  
**Plate 55: Scratched date above the stair head in the attic**  
**Plate 56: Truss 4**

# **North West Wales Dendrochronology Project**

## **Plas Tirion**

**SH 81043 59121**

### ***Introduction***

This report details the recording of the house at Plas Tirion, Llanwrst, Conwy, undertaken to compliment both the dendrochronological sampling, undertaken by Oxford Dendrochronology Laboratory, and the documentary study undertaken by volunteers for the North Wales Dendrochronology Project. The fieldwork took place at various points in 2011 and 2012. During this period the house was in the process of being restored by the tenants.

### ***Methodology***

The ground floor and first floor plans were adapted from drawings made by A. Voelcker, as part of the restoration programme. The drawings of the timberwork were carried out by direct measurement at a scale of 1:20. Photographs were taken with a Nikon D80 digital SLR camera at a resolution of 10.2 mega pixels. Where practical all the photographs included a metric scale.

### ***Survey Report***

Plas Tirion lies approximately 2.8 km SSE of the centre of Llanwrst. The house is set back from the A470 by about 150m occupying a slight shelf on the eastern valley side of the Afon Conwy. The house is part of a complex of buildings including a range of agricultural buildings and the "Old House". The "Old House" is the subject of a separate report (Brooks 2012). The house has long been known for its fine plaster work (e.g. Smith 1988, Plate 87). Hubbard (2003, 238) has speculated that Plas Tirion was originally, or was planned to be, an "E" planned house, however a recent resistivity survey (Brooks 2011) has demonstrated that the northern wing was never constructed even if it was planned.

Although the drive now approaches from the south Plas Tirion faces WSW, with a rough "F" shaped plan consisting of two ranges set at right angles and a three storey porch on the front elevation. To the rear there is a further projection to incorporate the stairs. The front elevation (Plate 1) consists of three main elements, the southern range, the main range and the double storeyed porch. At the time of the original survey the upper storey was partly rendered with a cement based render, however, since the survey this has been removed and the whole of the house has been lime washed. The southern range project from the front elevation and is constructed of roughly coursed stonework with no evidence for the use quoins. Whilst the windows on the western gable end of this range are multi-paned windows with slate lintels, which are later insertions, a small window



on the ground floor of the northern face (Plate 2) may be original. This window has a slate lintel and cill together with an iron bar dividing the opening. Above this window, although not evident before the render was removed, was a blocked doorway (Plate 3). The position of this door is curious; it is at first floor level with no obvious related features. It is not certain as to whether this was an external door, possibly accessed by a wooden stair flight, or if this door gave access to a range which is now lost. There are two ridge chimneys on the main range, both of which have tall square stacks. They are positioned on the northern gable end of the main range and over the join between the southern range and the main range.

The porch is a three storey extension to the main range. It has a cyclopean door head with large stone jambs (Plate 4) defining an open porch. The windows on the first and attic floor levels are later insertions as is shown by the brick packing which was revealed when the render was removed.

The southern elevation (Plate 5) was not rendered, revealing the poorly coursed stonework of its construction. There is a stone staircase attached towards the western end which gives access to the first floor level of the building. Partly built over these stairs is a single storied porch (Plates 6 and 7). Although this is limewashed, it would appear that there is a stone cyclopean, arch to the opening and large stone jambs. It has a gabled roof covered in, thick, moss slates (Plate 8), some of which show signs of having been re-used with nail holes on their distal ends.

The eastern gable wall of the southern range has a blocked opening, apparently a window (Plate 9), which is partly blocked by the construction of the later chimney on this end of the building. During the course of the restoration part of the blocking was removed, revealing a wooden frame, still *in situ*, with ovolo mouldings (Plate 10). The position of this window is curious, as occupies a space between the floors. It is possible that this opening relate to either a lost stair case or a possible wardrobe. There is no evidence on the inside of the building of this window, however, the later construction of the chimney on this end of the building has obscured or destroyed any internal evidence. The chimney has a straight joint between its structure and the gable end of the southern range. It also has a tall square stack

The three storey, stair tower on the rear elevation (Plate 11) is clearly a later addition to the main range as there is a straight joint in the masonry between the two structures. Externally the stair tower is constructed of random stonework with larger stone blocks used as quoins. There are two window openings in the eastern gable end, the lower of which has a segmental brick arch, whilst the upper window has a slate lintel. The lower window would appear to be a later insertion and there is a hint in the stonework that this opening may have been much taller. Attached to the northern end of the stair tower is a two storey extension, the lower floor of which appears to have been a service room; whilst above there is a bathroom. This range has straight joints between it and both the

stair tower and the main range of the house demonstrating that it is a relatively late in the development of the house. The relationship between the extension and the main range is rather uncomfortable, with the northern wall of the extension joining the main range immediately adjacent to the windows (Plate 12). These windows are multi paned with ovolo moulded mullions and slate lintels.

The northern gable end of the main range (Plate 13) has a single opening on the ground floor. This is a window; however, there is a scar below the window suggesting this opening may have been a doorway. This opening led to the theory that there may have been a northern wing to the house to complete a “E” shaped plan (Hubbard 2003, 238). A recent geophysical survey and watching brief, however, has shown that even if this range was planned it was never built (Brooks 2011). There is also a gable end chimney on this end of the main range with a tall square stack.

On the ground floor Plas Tirion is now divided into three main rooms, although before the restoration the southern (kitchen) range was divided into two rooms and an internal lobby and there was a wooden partition forming a corridor in the main range (Figure 3). The kitchen is dominated by the fireplace at the eastern end of the room. Before the restoration this contained a brick fire surround (Plate 14) within a relatively shallow recess. The removal of this structure revealed a much deeper hearth (Plate 15) with a large wooden lintel. There was also a mantle shelf over the hearth with two wooden hooks (Plate 16) of unknown function. To the north of the fireplace was a wooden screen (Plate 17) which was slightly angled so that it screened the fireplace from the doorway to the main range. It also provided a series of high level shelves for storage. Two beams cross the kitchen, both of which are chamfered and have straight stops. In the north west corner of the kitchen, although before the restoration it was in the scullery, is a small window with a slightly splayed reveal and an iron glazing bar (Plate 18). The small size of the opening and its form suggest this may be the only early window surviving in this range of the building.

The access to the main range is now in the north eastern corner of the kitchen. Before the restoration this gave access to a corridor running alongside of the eastern side of the hall, although now it gives direct access to the hall. This doorway appears to have been a later feature as during the conservation process the remains of a cupboard with a wooden frame was discovered which was cut by the doorway (Figure 7, Plate 19). Although the frame is relatively crude, there was the remains of a plaster surround which suggests that there may have been ovolo mouldings around this cupboard. The original doorway was on the opposite side of the fireplace in the hall. Hidden by cupboards on both side the doorframe of the original access between kitchen and the hall survives (Figure 6, Plate 20). The frame has ovolo mouldings (Plate 21) and a stone threshold. The form would suggest that this was an internal door linking the two ranges, although it is possible that it replaces an earlier external door.

The hall is dominated by the fireplace with its plaster overmantle (Plate 22), consisting of the interlinked initials R, W and K (Plate 23). Before the restoration this design was truncated by the ceiling; however the full design extended beyond the level of the lath and plaster ceiling. The restoration of this fireplace revealed the extent of the wooden bressumer and fragments of plaster ovolo mouldings (Plate 24) which originally surrounded the fireplace.

The parlour at the northern end of the main range has a more complex plaster overmantle (Plate 25). This incorporates an armorial together with the initials "RW KW" and the date 1626 within a strap work design. To the west of this overmantle is a cupboard (Plates 26 and 27) with twin doors and a double bowed head. The hinges on this feature (Plate 28) are H-hinges of late seventeenth century type (Alcock and Hall 1994, 25).

On the first floor (Figure 4), the southern range is divided into two rooms. These two rooms are not interconnected, leaving the western room (Room 1) only accessible via the stone step on the southern elevation of this range. Although there is no external evidence for a chimney stack there is a block fireplace in the southern wall (Plate 29). This fireplace is also above the current entrance to the kitchen so there is no evidence for a ground floor fireplace in this location. A recess in the north west corner corresponds with the blocked doorway seen on the outside of the building.

Room 3 was clearly a first floor hall. It contains an impressive, plasterwork, overmantle (Plate 30). An armorial is centrally placed over the hearth incorporating the motto "SINGULA IN UNO" within a ribbon. The date 1628 is incorporated within the design which is framed with strapwork (Plate 31). Flanking the armorial are figures of "War" and "Peace" shown as female figures (Plates 32 and 33). "Peace" holds a palm frond whilst the lower arms of "War" are missing, but presumably originally held a sword. Both characters are within arch topped niches. Below the overmantle the hearth is framed by mock columns supporting the figures and a frame of strapwork incorporating some floral designs. As with the overmantles on the ground floor, the ceiling of Room 3 truncates the top of the plasterwork suggesting that the original ceiling was at a higher level.

The room has small-field panelling which was originally reflected in a partition at the northern end of the room forming a passageway to the closet. This, probable nineteenth century feature was removed as part of the restoration revealing a stud and panel partition (Plate 34, Figure 10). Constructed of a series of nine upright studs between sill and head beams and with wattle and daub panels, this partition incorporates two, blocked doorways. Both of the doors had wooden, segmental, arched, doorheads, however a centrally placed nick was used to suggest an ogee head (Plates 35 and 36). These two doors originally gave access to Rooms 4 and 5, however these doorways were moved to the extreme ends of the partition presumably at a similar time that a partition was constructed along the eastern side of Room 3 forming a corridor between Rooms 2 and 5. This partition was designed to reflect the appearance of the stud and

panel partition with a series of upright studs separated by wooden panels (Plate 37). The upper portion of this partition is a separate panel which runs only between the chimney breast and the partition between Room 3 and Rooms 4 and 5. Outside Room 3, within the corridor, the southern end of the upper panel is marked by three turned spindles (Plate 38). The secondary nature of this partition is also suggested by a swelling in the transverse ceiling beam (Plate 39) running across both Room 3 and the corridor. This would suggest the presence of a post in the centre of the room before the partition was built.

Restoration work within the first floor corridor re-opened a window which was probably blocked when the stair tower was constructed or modified. The original window frame (Figure 8, Plate 40) was found *in situ*, although the northern end of this frame had been truncated by the construction of the stair tower. The frame had ovolo moulded jamb and chamfered lintel and sill. The surviving mullion was also ovolo moulded (Figure 9) and there was also an intermediate, rectangular bar set diagonally.

Room 4, in the north western corner of the first floor, has a plaster overmantle incorporating an armorial within a strapwork design (Plate 41). The wall between Rooms 4 and 5 initially appears to be a post and panel partition (Plate 42), however the “posts” prove to be of plasterwork and this is an attempt at disguise the wall as a more complex construction than it really is.

Room 5, also has a plasterwork overmantle (Plate 43). This incorporates an armorial with the date “1626” above and the initials “RW KW”. The window in this room has three ovolo moulded mullions (Plate 44).

Although externally the stair tower would appear to be constructed of stonework, internally there is some evidence for a timber framed structure (Plates 45 – 47). It is possible that an initial timber framed stair tower was later clad in stonework, although this remains speculative. The stairs themselves proved to be later replacements as the restoration recovered a series of ovolo moulded mullions which had been used to support the stair case (Figure 9).

The attic consists of five interlinked rooms (Figure 5). Attic 1 is within the southern range and it contains Trusses 1 and 2 (Figure 11, Plate 48). Both of these trusses are of simple collar beam type with trenched purlins and a slightly curved collar. They also retain red chalk carpenters markings defining the depth of the trenches for the purlins. Truss 1, however, also has a series of dowel holes (Plate 49) above the collar and mortice holes below suggesting the presence of a partition below this truss (Plate 50). Truss 2 is slightly chamfered below the level of the collar, both on the principal rafters and the lower edge of the collar. There is also some scratch marking (Plate 51) which appear to be a series of “1”s and “0”s

Truss 3 (Figure 12, Plate 52) separates Attic 2 from Attics 3 and 4. This truss, like Truss 4, is a tie beam structure with raking struts. There is a doorway below this



truss which has a wooden door head with segmental arch (Plate 53). This door head would appear to have been lifted by about 0.28 m. There are also a series of mortice holes in the beam above the door head suggesting the presence of a wattle and daub partition above the door. The roof in this wing has been lifted and a second set of principal rafters added on top of both Trusses 3 (Plate 54) and 4. The date of this lifting is hinted by the scratched date of 1836 together with the initials "WH" in the plasterwork of above the stair head (Plate 55).

Truss 3 (Figure 12, Plate 56) is between Attics 3 and 4 and Attic 5. It has similar characteristics to Truss 3, although there is no door head, even though there is an opening below this truss.

### ***Dendrochronology Sampling***

A total of eight samples were taken, by Oxford Dendrochronology Laboratory (Miles and Bridge 2012). These sampled the two transverse beams in the kitchen in the southern wing and the mantle beam, two principal rafters and a purlin in the northern wing. Only one timber securely dated, a transverse beam in the southern range, which gave a date of 1565. The timbers from the northern wing did not give secure dates, although a construction period similar that on the plasterwork (1626 and 1628) is possible. Miles and Bridge did suggest, however, that these timbers had originated from trees which had been managed in some way during their life.

### ***Conclusions***

Plas Tirion is a gentry house of some standing within the Conwy Valley. Clearly has a complex history with at least two major phases of construction and probably multiple other modifications. It is likely that the building which is the subject of this report replaced an earlier house approximately 30 m to the south (Brooks 2012). The dendrochronological dates for the house suggests that the two main ranges are of separate dates with the southern (kitchen) wing being constructed 1565 and the main range probably in the early seventeenth century, possibly contemporary with the dated plasterwork within some of the rooms. This however gives a simplistic view on the development of the house.

The original (southern) range has a number of features which suggest that it developed from its original form. The chimney has been added to the eastern gable of the range, partially blocking a window. The position of the original chimney is not certain; however the blocked fireplace within Room 1 might suggest the possibility of a lateral chimney. If this is so, the current door to the kitchen must therefore be a later feature. It is possible that the 1565 house originally faced north, with the access to the house from the hollow lane to the north of the current house. The presence of a blocked doorway on the first floor level of the northern elevation is curious. There is no surviving evidence for an external staircase to this doorway, possibly suggesting this was an internal door to a missing range. There could, however, have been a wooden flight of stairs

giving access to the first floor level. The blocked window in the eastern gable, between the ground and first floor levels, possibly marks the position of the staircase for the original house, although this remains speculative. It is assumed that the division of the first floor into two unconnected rooms took place late in the development of the house, possibly in the nineteenth century. This would allow farm workers to be accommodated away from the family. It is likely that the stone steps and the porch were also added at this time. It is noticeable that the barn in the farm complex to the south of the house has a date plaque of 1837 and it is possible that the modifications relate to the construction of the track between the farm and the house which also truncated the “old house”.

It is likely that the main range was constructed in the early seventeenth century, possibly shortly before the plaster overmantles were added to the fireplace. The complexity of the overmantle in Room 3 would suggest that the main reception room intended to be on the first floor. It is also likely that the rooms interconnected directly with no corridors along the eastern side of the range. Similarly the access between the southern range and the main range was to the western side of the hearth in the main range. Possibly in the eighteenth or early nineteenth century the corridors were added, this however also required the cutting of a new doorway between the kitchen and the main range. As a result a cupboard in the wall adjacent to the hearth in the ground floor hall was truncated. Evidence from the few surviving windows and the find of re-used mullions as stair supports would suggest that the seventeenth century range had ovolo mouldings throughout which were also matched on the doorframes and fire surrounds.

The apparent “F” shaped plan is coincidental from the development of the house. There is no evidence for a third wing having been construction from neither the geophysical survey (Brooks 2011) nor a watching brief carried on a trench cut across the field to the north of the house. The presence of a partially blocked opening, now occupied by a window, may suggest that there may have been a plan for a third wing which was never realised.

The stair tower would appear to be a later addition; however it is possible that it was a timber framed construction to which a later skin of stonework was added. This stonework also required a first floor window to be blocked leaving the first floor corridor without a direct source of light. A further extension to the north of the stair tower is probably nineteenth century in date.

### ***Acknowledgments***

The recording of this building was commissioned by Margaret Dunn for the North Wales Dendrochronology Project. Thanks are also due to the tenants for access to this building.

## References

- Alcock N.W. a Hall L. 1994 *Fixtures and fittings in dated houses 1567 – 1763*. Council for British Archaeology Practical Handbooks in Archaeology No. 11.
- Brooks, I.P. 2011 *Plas Tirion Geophysical Survey*. Unpublished Client Report for The Snowdonia National Park Authority. EAS Client Report 2011/18
- Brooks, I.P. 2012 *Plas Tirion Old House, Llanwrst, Conwy*. Unpublished Client Report for the North-West Wales Dendrochronology Project in Partnership with The Royal Commission on the Ancient and Historical Monuments of Wales. EAS Client Report 2012/03
- Hubbard, E. 2003 *The Buildings of Wales. Clwyd (Denbighshire and Flintshire)*. Yale University Press, London
- Miles, D and Bridge, M.C. 2012 *The Tree-Ring Dating at Plas Tirion, Llanwrst, Conwy (NGR SH 810 591)*. Oxford Dendrochronology Laboratory Report 2012/26
- Smith. P. 1988 *Houses of the Welsh Countryside. A study in historical geography (second edition)*. HMSO London



Plate 1: Front elevation (2011)

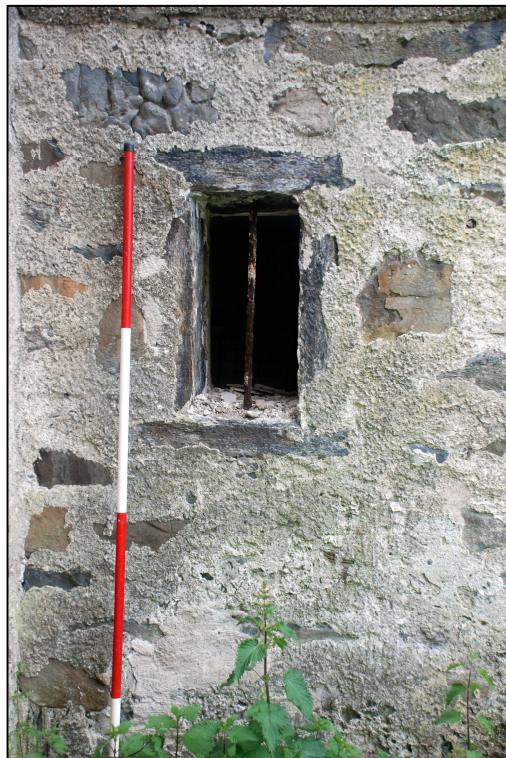

Plate 2: Window in the northern face of the southern range





Plate 3: Blocked doorway in the northern elevation of the southern range



Plate 4: The porch





Plate 5: The southern elevation



Plate 6: The porch on the southern elevation



Plate 7: The relationship between the southern porch and the stone stairs



Plate 8: The roof of the southern porch



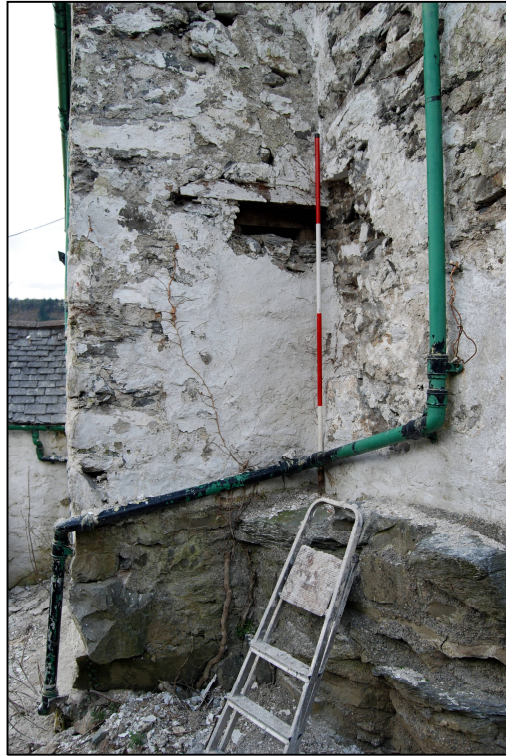

Plate 9: Blocked window in eastern gable end of the southern range



Plate 10: Detail of the window frame in the blocked window in the gable end of the southern range





Plate 11: The stair tower



Plate 12: The northern end of the rear elevation of the main range





Plate 13: The northern gable end



Plate 14: The kitchen fireplace before restoration





Plate 15: The kitchen fireplace after the removal of the later structures



Plate 16: Wooden hook on the mantel shelf above the kitchen fireplace



Plate 17: The screen adjacent to the kitchen fireplace.



Plate 18: Small widow in the north western corner of the kitchen





Plate 19: Remains of a cupboard cut by the doorway between the kitchen and the hall



Plate 20: Original doorway between the kitchen and the hall



Plate 21: Detail of the ovolo moulding of the doorway between the kitchen and the hall



Plate 22: The hall fireplace before restoration





Plate 23: Plaster overmantle in the ground floor hall



Plate 24: Remains of the plaster moulding around the ground floor hall fireplace



Plate 25: The overmantle in the parlour



Plate 26: The cupboard in the parlour





Plate 27: Cupboard doors in the parlour



Plate 28: Detail of the hinge to the cupboard of in the parlour



Plate 29: Block fireplace in Room 1

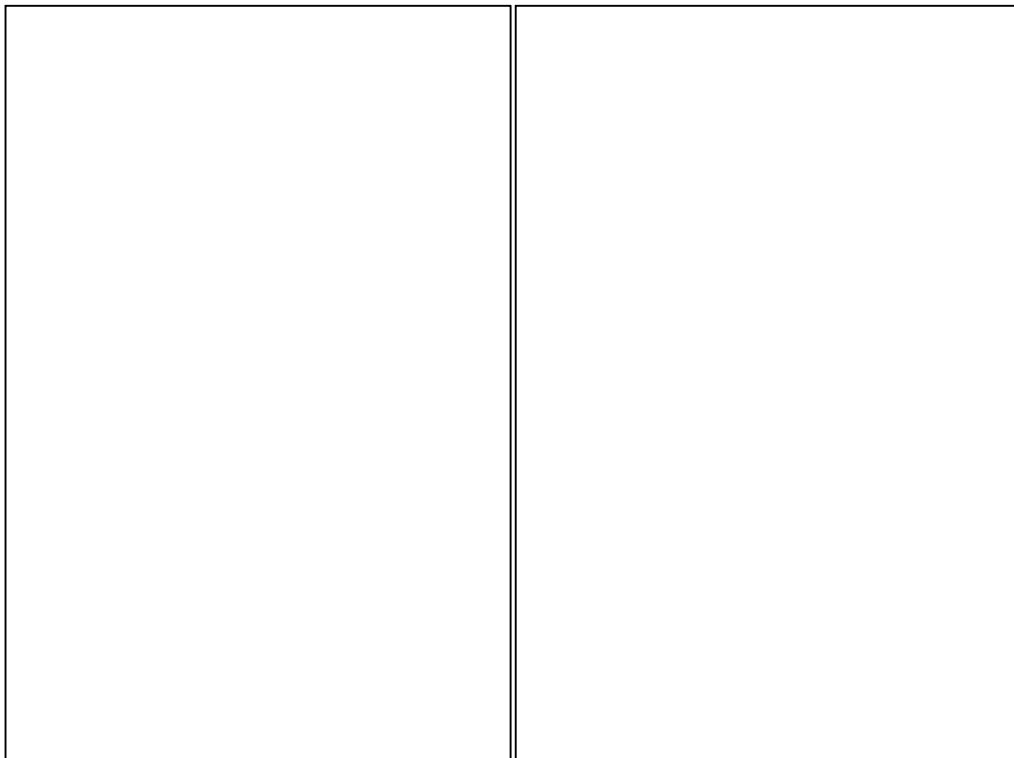

Plate 30: Plaster overmantle in Room 3





Plate 31: Detail of the overmantle in Room 3



Plates 32 and 33: Details of figures on the overmantle in Room 3

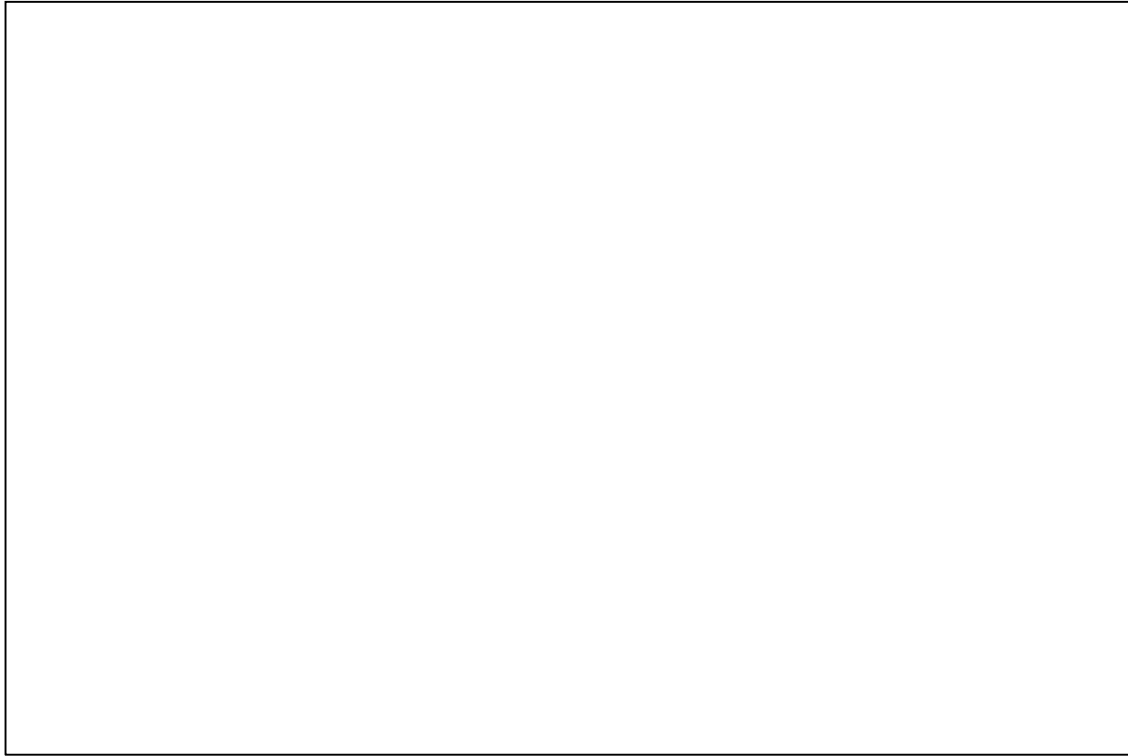

Plate 34: The partition between Rooms 3 and 4 and 5



Plate 35: Western doorhead in the partition between Room 3 and Rooms 4 and 5

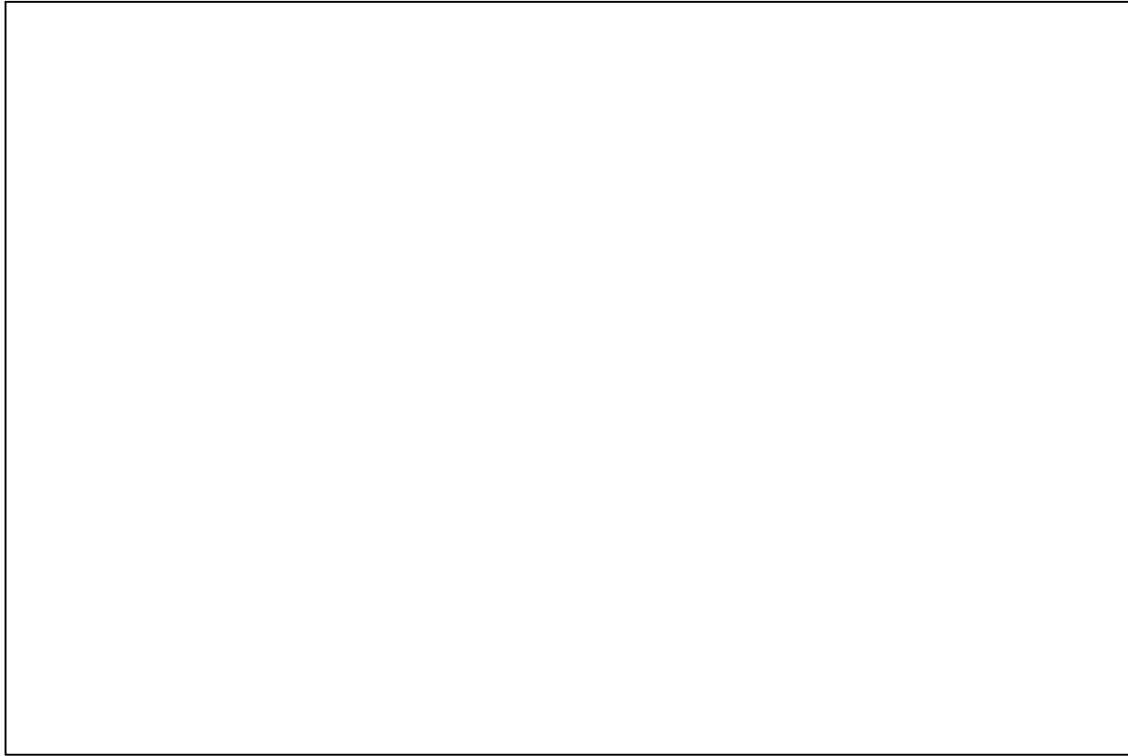

Plate 36: Eastern doorhead in the partition between Room 3 and Rooms 4 and 5

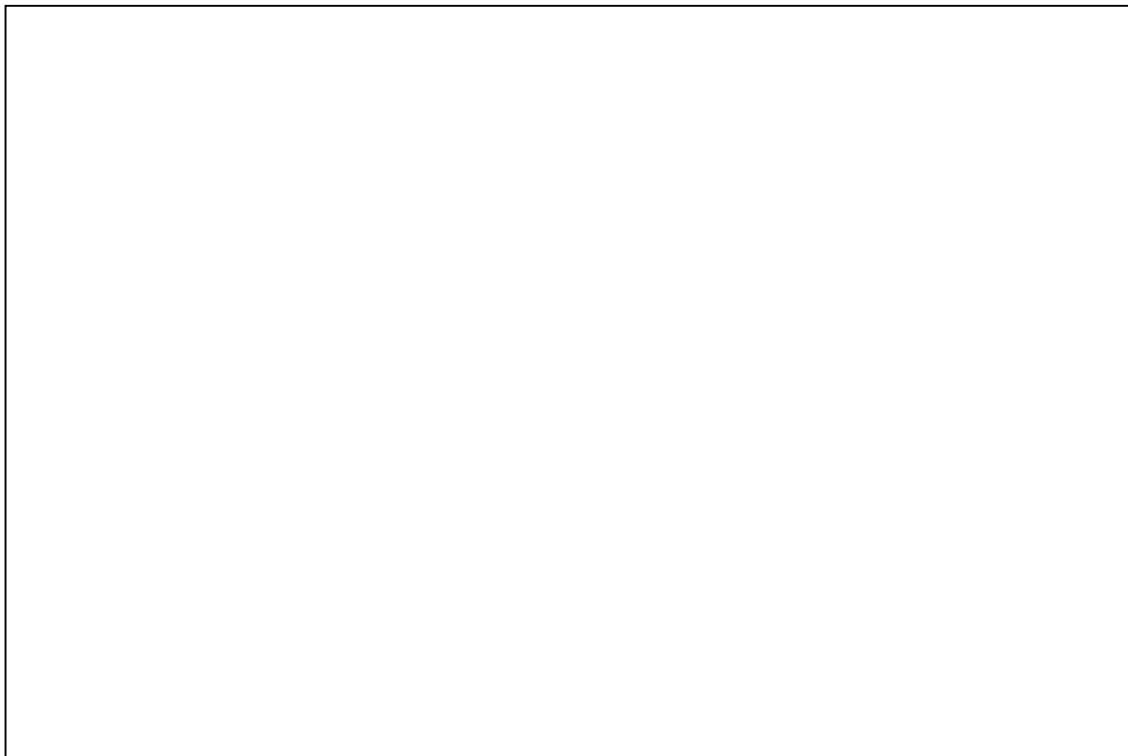

Plate 37: The partition between Room 3 and the first floor corridor

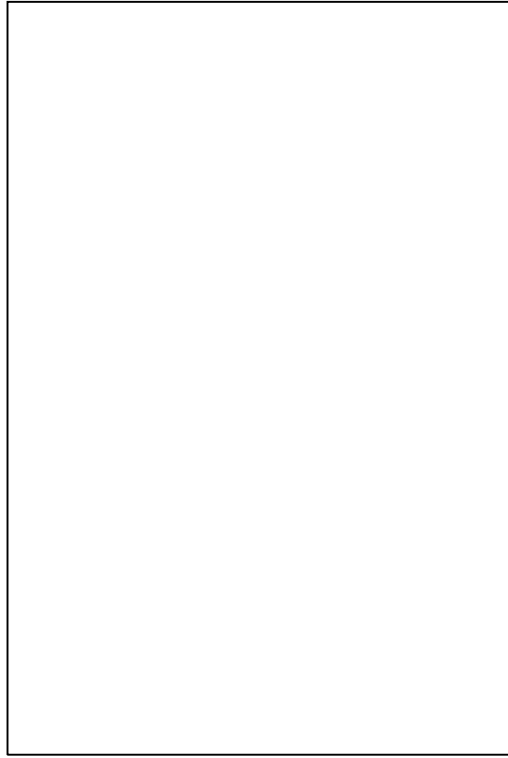

Plate 38: Turned spindles in the partition between Room 3 and the corridor

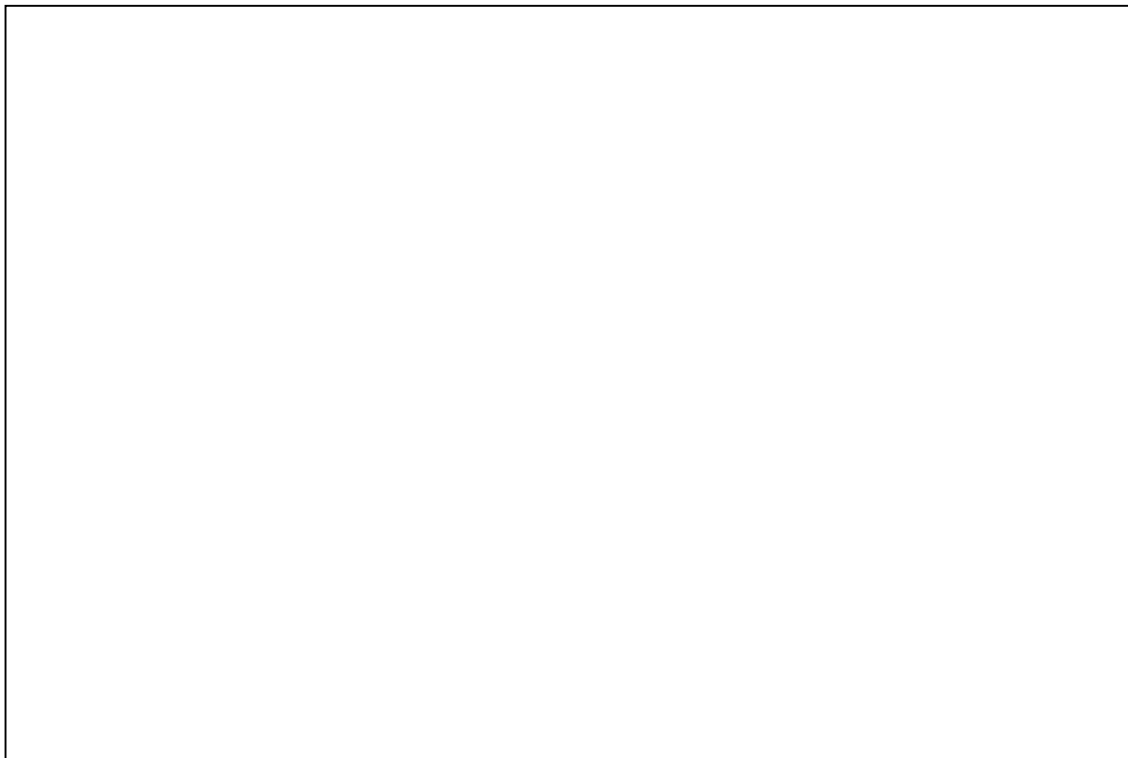

Plate 39: Swelling on the ceiling beam in Room 3

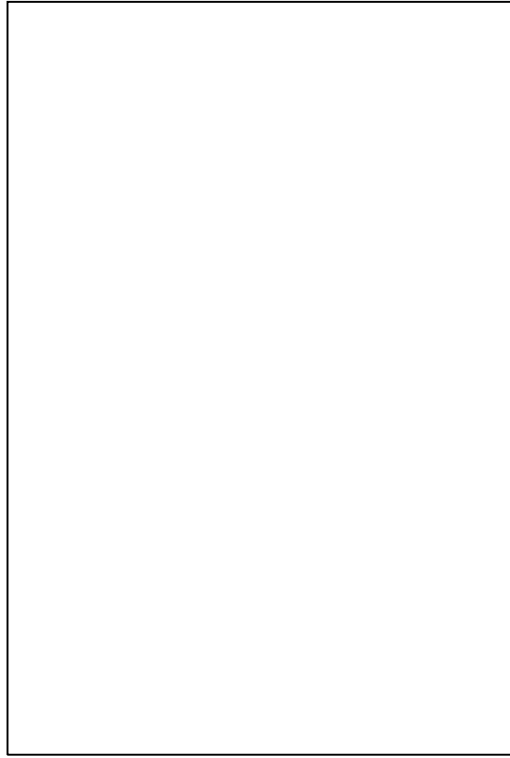

Plate 40: Blocked first floor window



Plate 41: Overmantle in Room 4

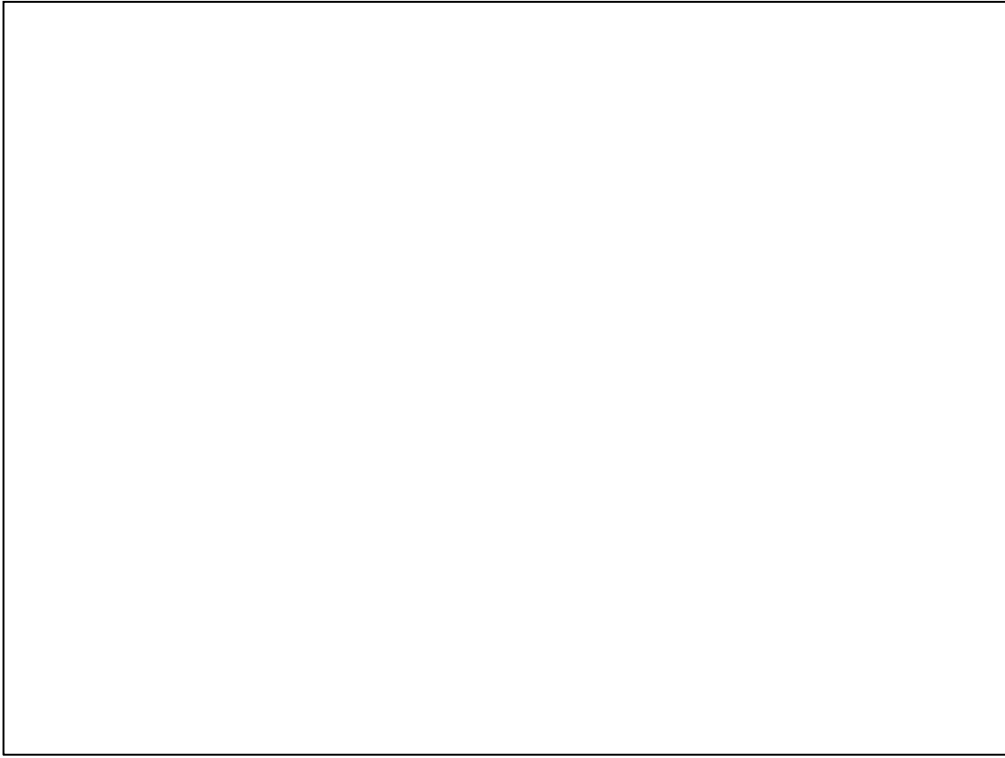

Plate 42: Mock post and panel partition in Room 4

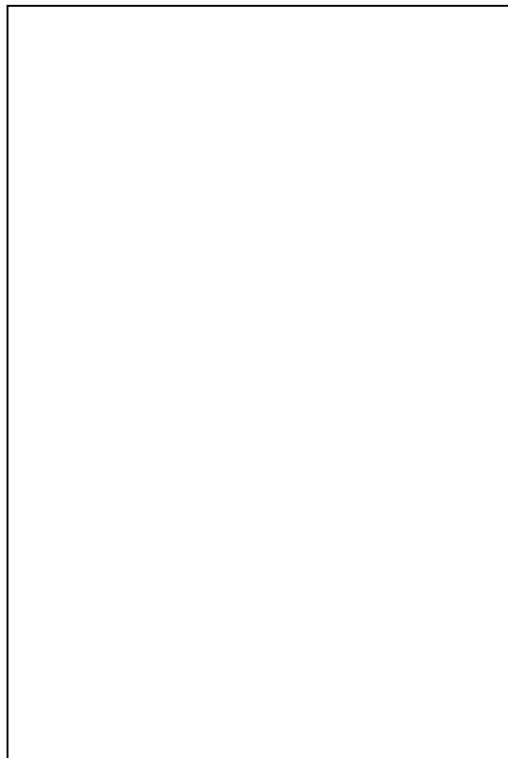

Plate 43: The overmantle in Room 5



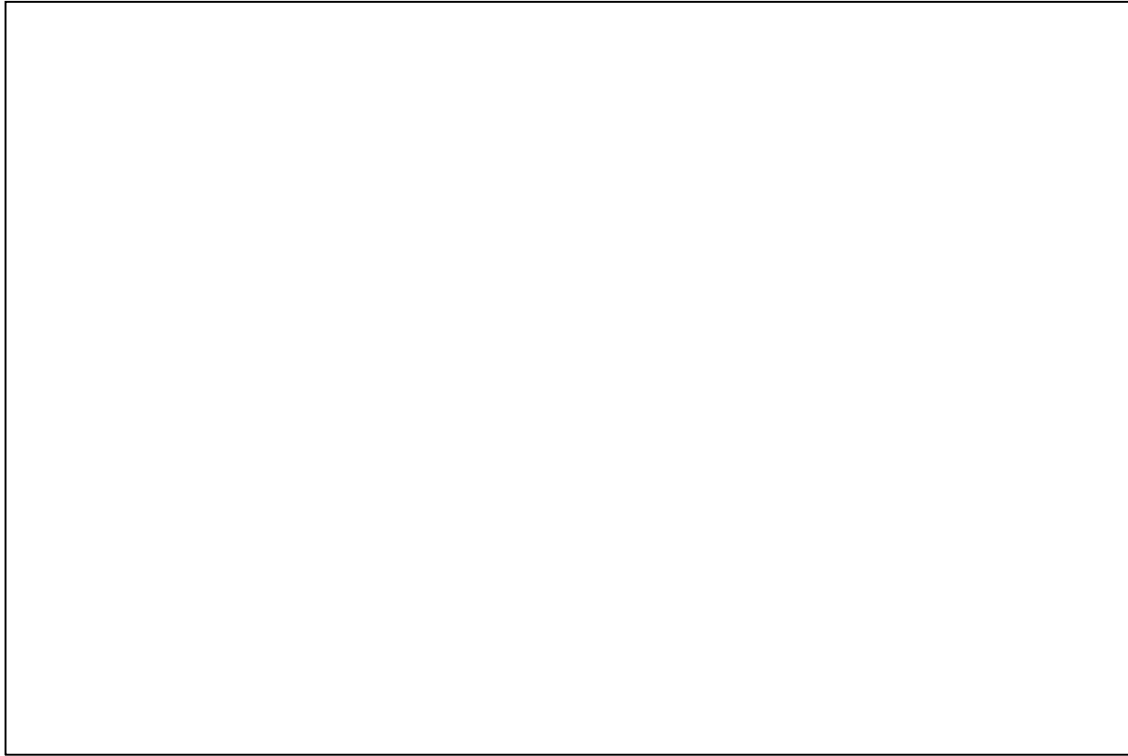

Plate 44: Ovolo moulded mullion in Room 5

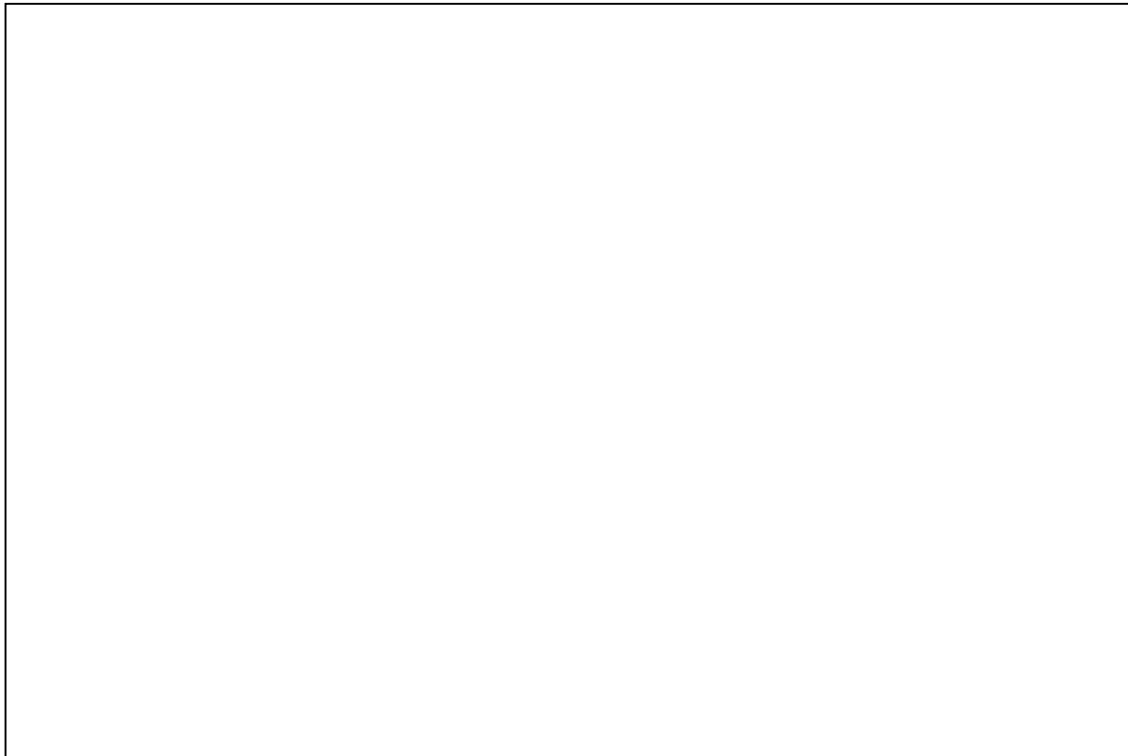

Plate 45: Timber framing in the stair tower



Plate 46: Timber framing in the stair tower

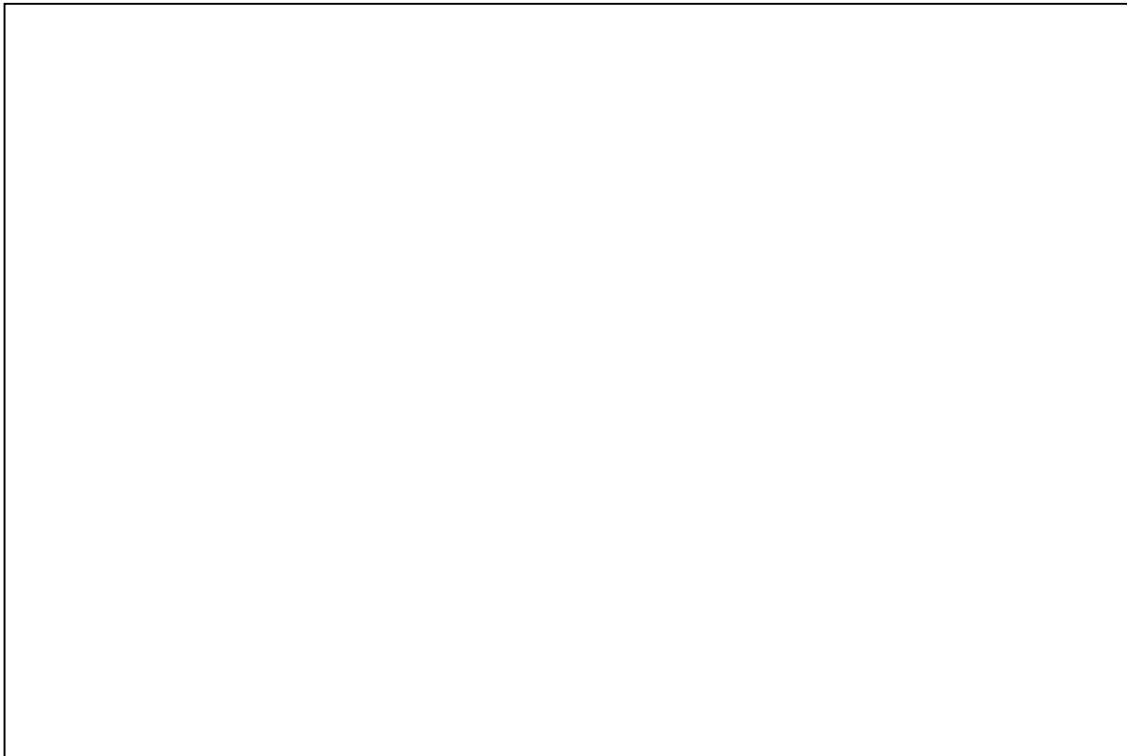

Plate 47: Timber framing in the stair tower

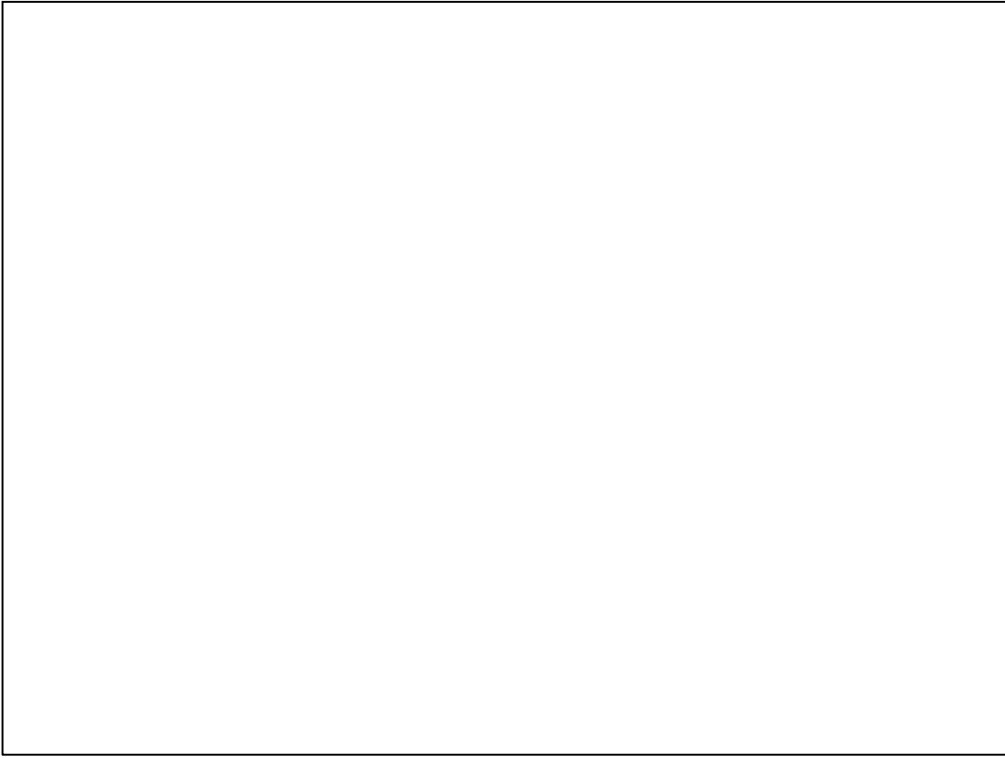

Plate 48: Truss 1

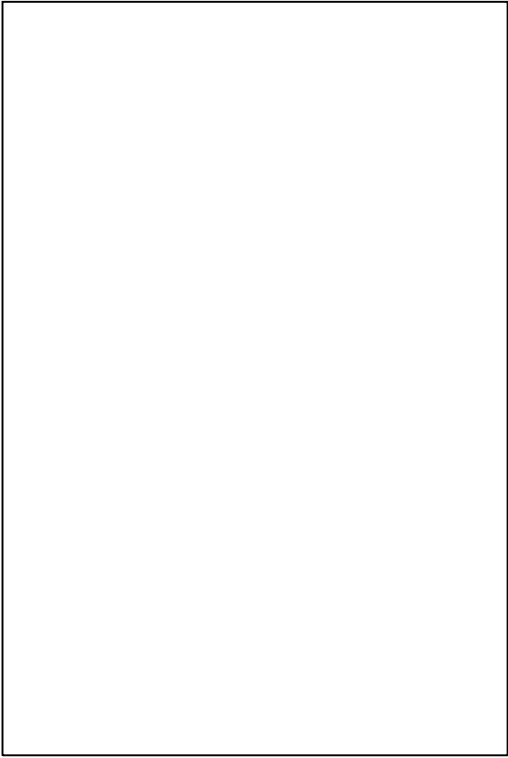

Plate 49: Dowel holes below Truss 1

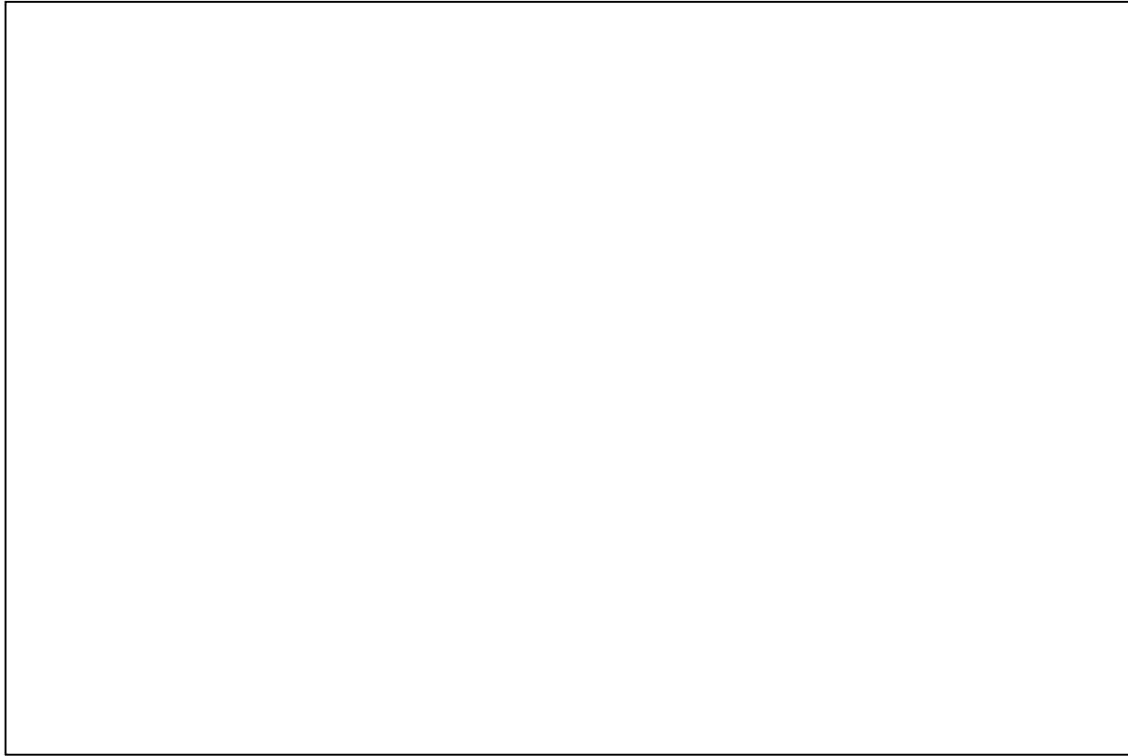

Plate 50: Dowel holes for mortice below Truss 1

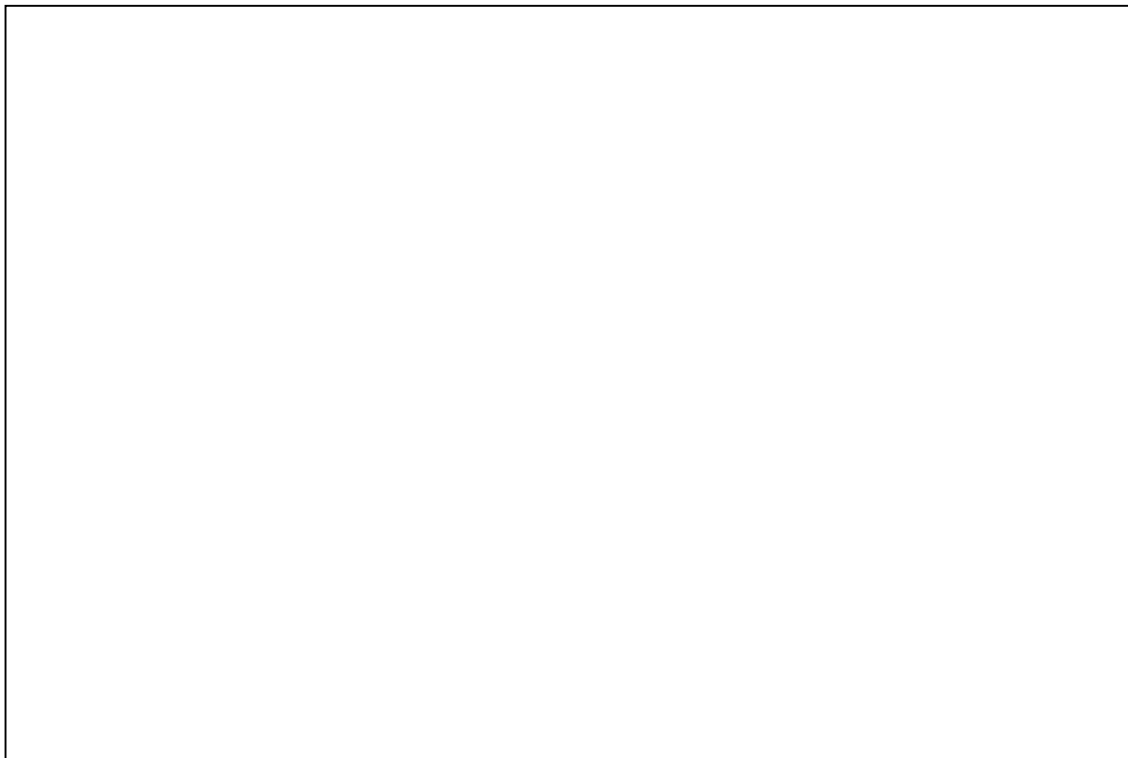

Plate 51: Scratch marks on Truss 2

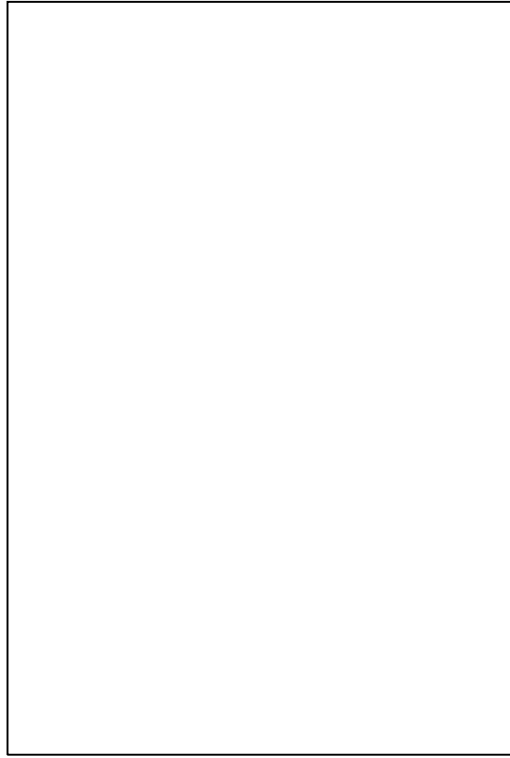

Plate 52: Truss 3

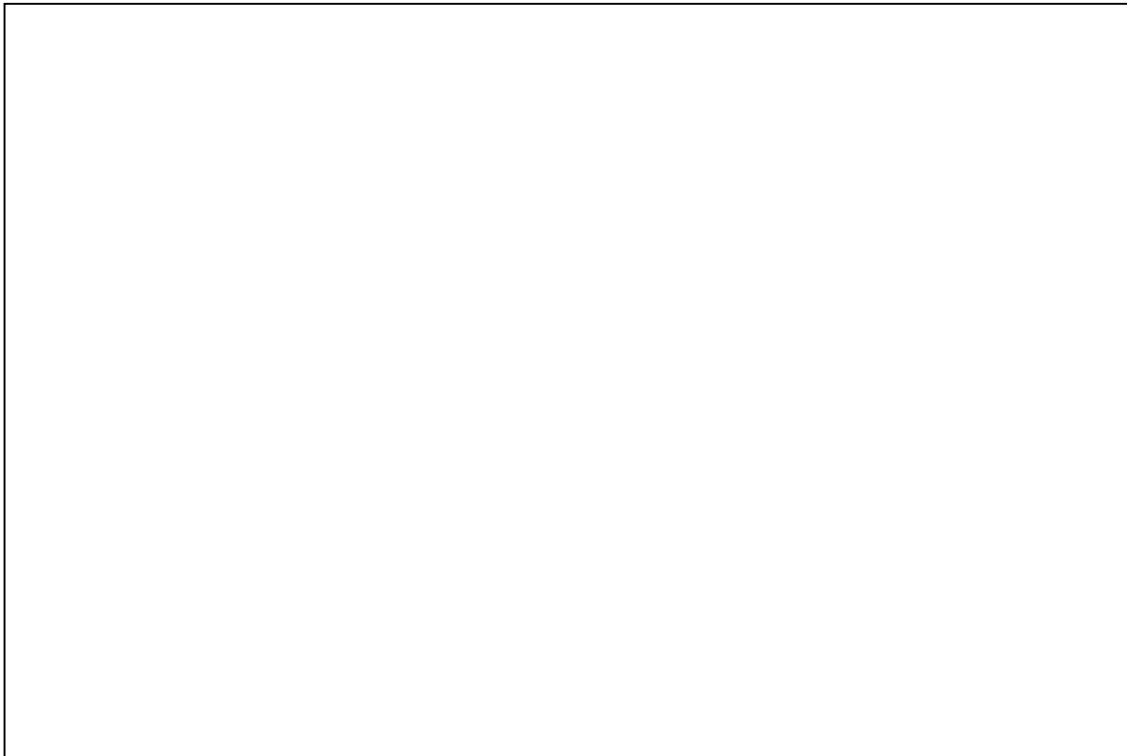

Plate 53: Door head below Truss 3

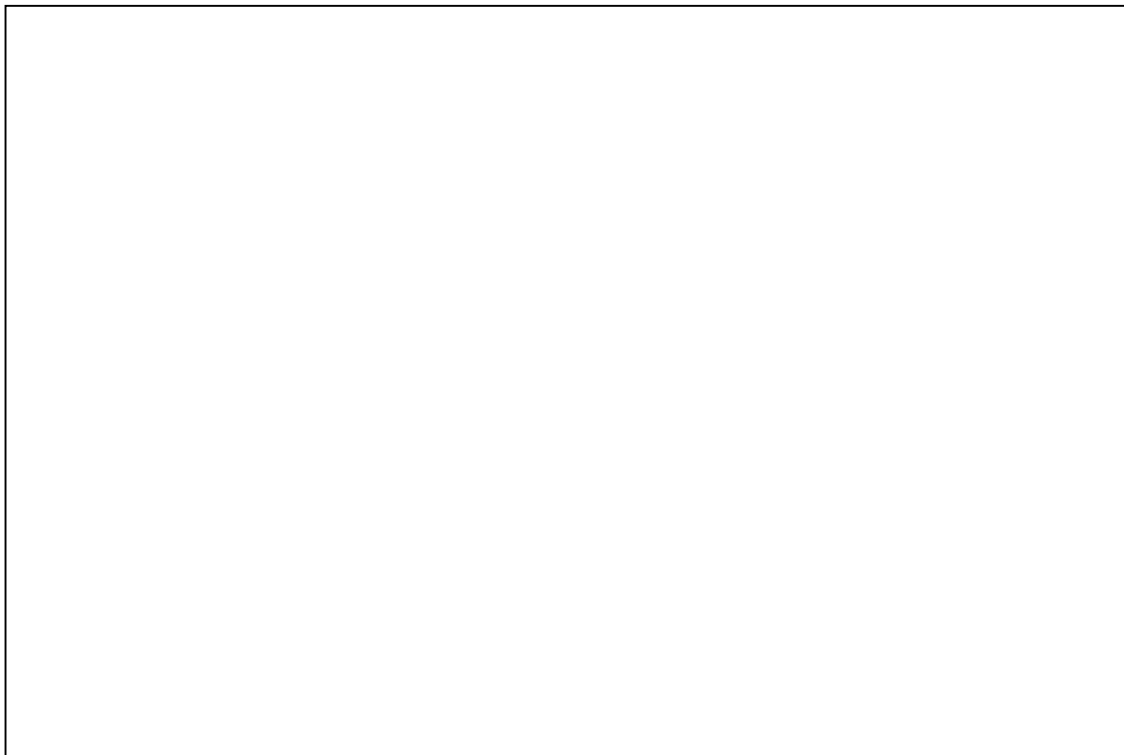

Plate 54: Secondary principal rafters, Truss 3



Plate 55: Scratched date above the stair head in the attic

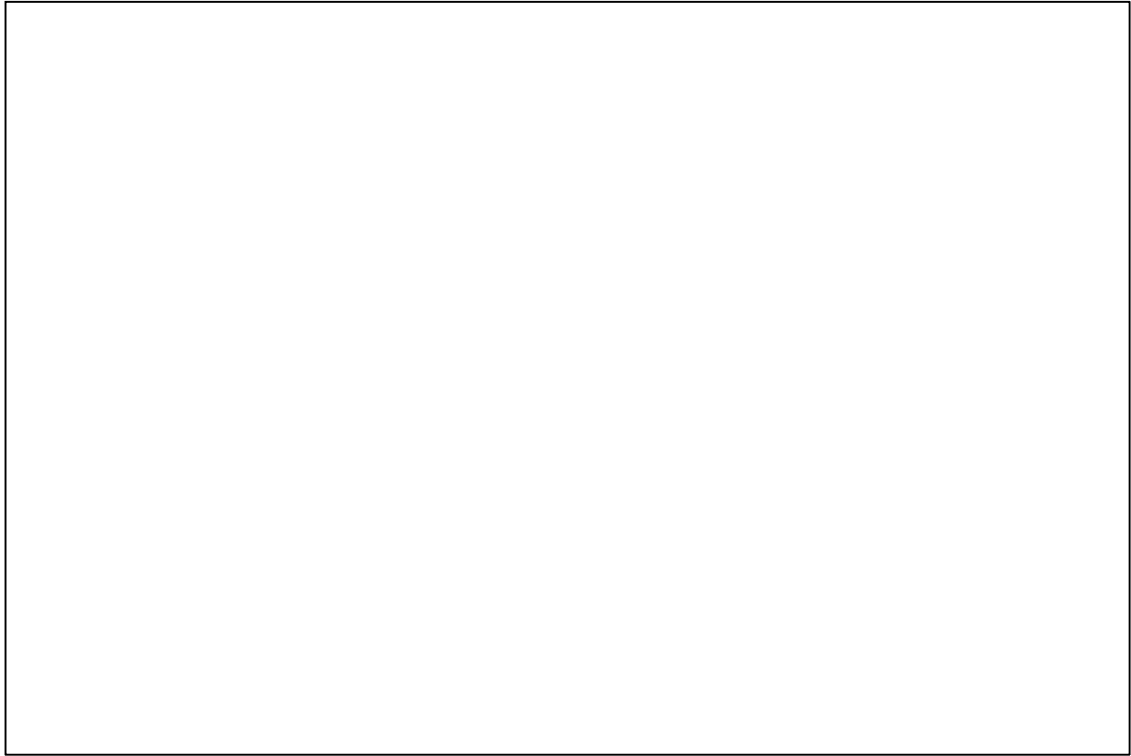

Plate 56: Truss 4

## **Appendix 1: Sources**

[http://jura.rcahms.gov.uk/cadw/cadw\\_eng.php?id=109](http://jura.rcahms.gov.uk/cadw/cadw_eng.php?id=109)

### **Plas Tirion**

**Street Name and Number:** A470,

**Listed Building Reference:** 109

**Date Listed:** 23/06/1967

**Co-ordinates:** 281049,359165

**Community:** Bro Garmon

**National Park:** Yes

**Grade:** II\*

**Date Amended:** 11/08/1997

**Locality:** A470

**Council:** Conwy

### **Location**

Prominently and imposingly sited, raised up slightly above the main Llanrwst-Betws-y-Coed road, and set back from it; accessed via a farm track running E from the road and sited across a hillslope.

### **History**

Large late C16 storeyed house of manorial scale and quality, originally conceived as an E-plan. One of a small number of gentry satellite houses built locally in the second half of the C16 for junior branches or members of the Wynn family of Gwydir; others include Berth Ddu and Cae Melwr. Interior cosmetic alterations appear to have been carried out between 1626 and 1628 for Robert Wynn and his wife Katherine; Robert (d.1640) was High Sheriff of Denbighshire in 1618. Five heraldic plasterwork overmantles dating from this intervention survive, together with some contemporary small-field panelling, some of which has been repositioned. Contemporary correspondence reveals that Richard Wynn, (subsequently Sir Richard, the fourth Gwydir baronet) was living here in the years 1657-9. In 1658 he served as High Sheriff of Caernarvonshire; the following year he took part in the Royalist revolt known as Booth's Rebellion, in association with his father in law Sir Thomas Middleton of Chirk. The left-hand cross-wing is missing and was either never constructed (although clearly intended), or, more probably, it was demolished before the late C19. Further, minor alterations at the end of the C17 included the creation of a fine wig closet in the first-floor porch room. Restoration works of c1837 (dated agricultural range) included some modification to window openings and some interior rejustification which involved the repositioning of some panelling.

### **Interior**

Small hall (reduced by C19 partitioning) with relocated C17 small-field panelling as draught screen to R of entrance. Plasterwork decoration above fireplace (opening reduced) with raised monograms R W K (for Robert and Katherine Wynn); built-in C17 panelled cupboard to R of fireplace, plastered stopped-chamfered beams. Small parlour beyond to R with similar ceiling and evidence of



a former partition to the R (removed this century). Large fireplace (reduced to L) with Tudor-arched, stopped-chamfered bressummer and good heraldic plasterwork overmantel with date 1626 and initials as before. To the L of the fireplace a second-quarter C18 soft-wood built-in cupboard; shaped tops to fielded panelled doors. Beneath this section is a cellar, now filled in. Further wide fireplace with chamfered bressummer and ceiling beams as before to former kitchen in cross-wing. Simple c.1700 segmental arched opening to original closed well stair, built around a central masonry pier; contemporary large-field panelling. Original random-width oak floorboards to first floor and attic, with C17 small-field panelled doors or c1700 2-panel (raised and fielded) doors to all first-floor rooms. The main first-floor chamber (originally the great chamber) has been reduced by the insertion of two partitions, one modern and the other, opposite the stair access, a probable C19 insertion; this now forms a corridor and appears to be made up of sections of a primary post-and-panel partition, with grooved decoration to the posts. C17 small-field panelling to the chamber proper, including a panelled window seat. Very fine large heraldic plaster overmantel with central arms and date 1628 within a strapwork cartouche; flanking classical pilasters support niched personifications of War and Peace; C19 grate. Beyond the modern partition, an original C16 timber-framed partition wall, partly obscured by further small-field panelling; 2 original openings (now blocked) with ogee-arched heads. Above the porch, a small chamber adapted as a wig closet in the later C17; panelled cupboards with original iron door-furniture flank a central entrance with panelled double doors, contemporary hinges and lock. Two further plaster overmantles in chambers to the NW, one with geometric decoration, the other, smaller one with date. The stair continues to the attic floor with original treads and risers and in unaltered condition. Huge stopped-chamfered collar trusses with original purlins; repair date 1836 cut into roof plaster. Original oak pegged doorcase to 3-bay crosswing; small fireplace in front corner. Plain upper porch chamber with partly renewed roof.

## **Exterior**

Large storeyed, gabled house of rubble construction with rough-cast render above ground-floor level. Slate roofs with plain gables and tall stone stacks; original moulded capping and weathercoursing. F-plan (though formerly E-plan) with projecting 3-storey gabled crosswing at R of 2-storey main block; the balancing wing to the L is missing. 3-storey gabled porch with segmental arch to cyclopean stone lintel; fine original heavy oak studded door within, with contemporary ironwork and ovolo-moulded doorframe. Irregular windows with C20 wooden-framed glazing and c1840 recessed slate lintels with labels to otherwise mostly original openings; cellar light to L section. Projecting gabled end chimney to rear of cross-wing with full-height gabled stair tower to R; adjoining this a C19 one-and-a-half storey catslide roof extension. Beyond, to the R, two original 4-light ovolo-moulded mullioned windows, one to the ground and one to the first floors, with plain glazing. The SE side has a further, single-storey gabled porch with round-headed entrance; oak frame with modern door. Within, an original studded oak door with ironwork and moulded frame as before. Adjoining

the porch to the L is a straight flight of slate steps leading to a first-floor entrance, a C19 alteration; boarded door. To the R of the porch a C19 20-pane sash window to the ground floor with a 16-pane sash above. A former first-floor lateral chimney is implied above the present porch by a blocked fireplace to the first floor chamber.

### **Reason for Listing**

Included at Grade II\* for its special historic interest as an important sub-medieval gentry house with fine surviving C17 interior plasterwork and panelling; one of the finest buildings of this type in the region.

### **References**

J. Ballinger, Ed., Calender of the Wynn Papers, 1515-1690, 1926, pp347-349;

W. Beazant Lowe, The heart of Northern Wales, Vol.2, 1927, pp302-305, figs.161-2;

E. Hubbard, Clwyd, Buildings of Wales series, 1987, p238;

P. Smith, Houses of the Welsh Countryside, 1988, maps 27, 48a.

<http://www.coflein.gov.uk/en/site/27773/details/PLAS+TIRION/>

## **PLAS TIRION**

**NPRN** 27773

**Grid Reference** SH81035910

**Old County** Denbighshire

**Type of Site** HOUSE

**Period** Post Medieval

**Map Reference** SH85NW

**Unitary (Local) Authority** Conwy

**Community** Bro Garmon

**Broad Class** Domestic

### **Site Description**

Plas Tirion, Bro Garmon, is a 16th century house of rubble construction with pitched slate roofs, plain gables, and tall stone stacks. The structure is F-plan (though formerly E-plan) with a projecting 3-storey gabled crosswing at the right of a 2-storey main block. There is a 3-storey gabled porch with a segmental arch and original oak studded door. There are Irregular windows with 20th century wooden-framed glazing and c.1840 recessed slate lintels with labels to otherwise mostly original openings. The south-east side has a further, single-storey gabled porch with a round-headed entrance and similar door. The building retains several original features internally, including the first-floor and attic floor boards and an oak pegged doorcase.

(Source: Cadw listing description)

J Hill 21/06/2004

### **ADDITIONAL:**

Plas Tirion is a multi-period complex in the Conwy valley. Below the principal house there are several ranges of farmbuildings which include an earlier house.

1. The multigabled principal house commands a view over the Conwy valley. It is a winged gentry house with a T-plan hall range and cross-wing, and with storeyed porch and stair forming front and rear projections. The ground floor has a three-unit plan with parlour, hall, and kitchen cross-wing. The hall range has ovolo-moulded detail (beams, windows and door frames) and several plaster overmantels dated 1626 and 1628. The three-storey cross-wing has a roof of collar-beam trusses; the two-storey hall range has a tie-beam roof with raking struts. Dendrodating of the dated 1626-28 N hall range failed to produce a convincing match. However, tree-ring dating gave a date of 1565 for the S kitchen cross-wing.

2. The farmbuildings below the house include a dilapidated range that incorporates a distinctive cruck-truss with blades of boxed heart (whole tree) rather than halved timbers. The cruck and purlins are heavily smoke blackened and belonged to a medieval domestic building. This is the passage end truss of a downslope sited range which has been reconstructed beyond the lofted end bay, although some framing of uncertain date is incorporated in the stone walls.

Whole-tree crucks are found among early pre-1400 crucks in England (but which have proved elusive in Wales). In the event, sampling showed that the trees were felled at the end of the fifteenth century, perhaps when large trees were not available. The cruck is associated with a later cross-beam in the passage which may relate to an inserted floor.

Dendrochronology has therefore established an interesting and in some respects unexpectedly detailed chronology for the site:

1498 cruck-framed hall-house

1545/46 inserted beam (loft) at passage end of hall-house.

1565+ Snowdonian house (= S Wing)

1626-8 Enlargement, with the Snowdonian house becoming kitchen wing of the new range.

NPRN27773. R F Suggett/RCAHMMW/July 2012.

**Hubbard, E. 1994 *The Buildings of Clwyd (Denbighshire and Flintshire)*. Yale University Press, London**

PLAS TIRION, 1 ¼ m. SSE. The front was, or was to have been, of E-plan, with three-storied cross wings and porch, but the left hand wing is missing. In a ground-floor room, a plaster overmantle, with heraldry and strapwork, is dated 1626. The same date, with initials and heraldry, occurs above an upstairs fireplace. A further first-floor chimneypiece has heraldry and strapwork, and there is a more elaborate one of 1628.

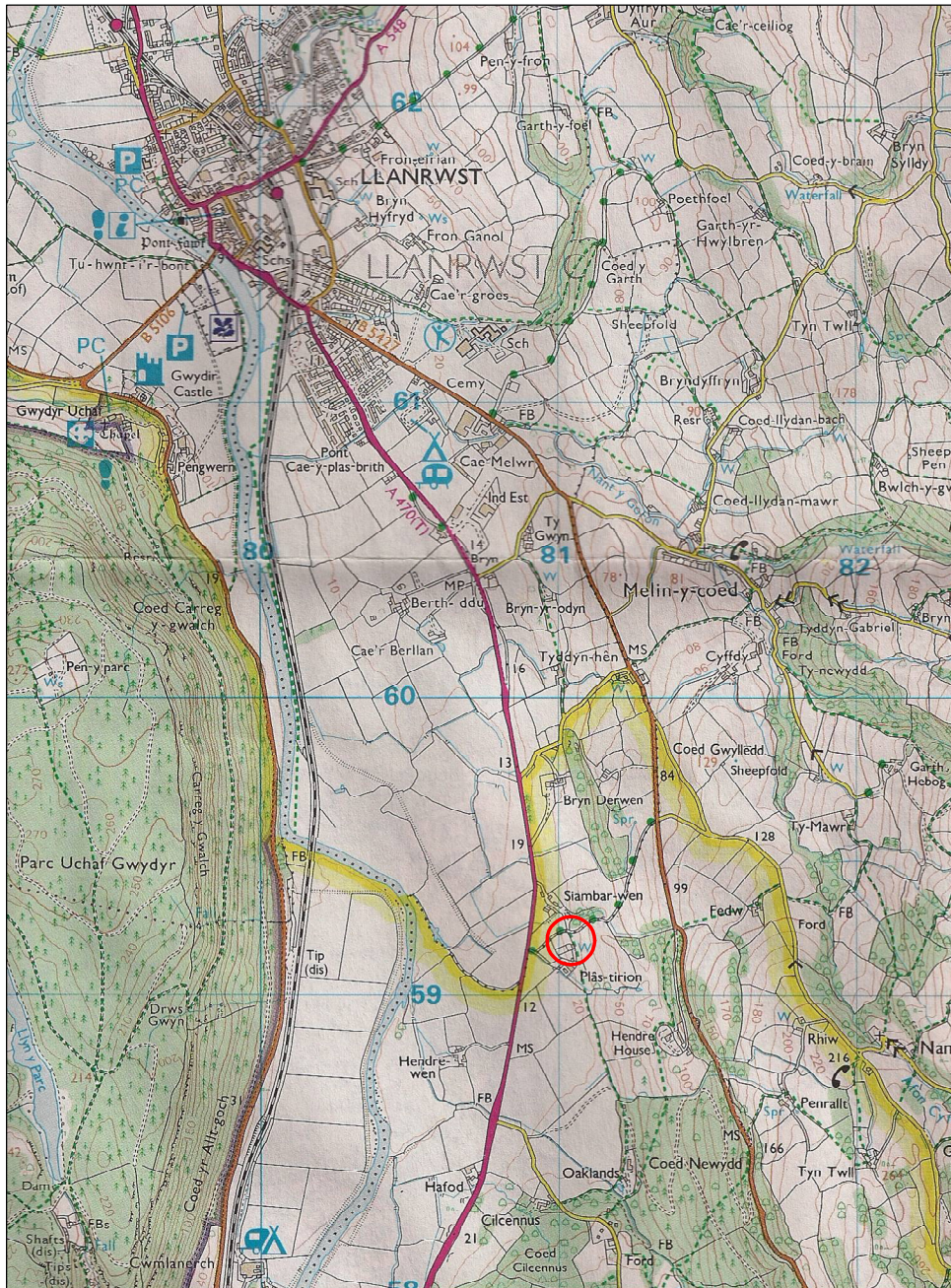

Figure 1: Location  
Scale 1:25,000

Reproduced from the Explorer™ OL17, 1:25,000 scale  
by permission of the Ordnance Survey ® on behalf of  
The Controller of Her Majesty's Stationary Office  
© Crown Copyright 2002  
All Rights Reserved Licence Number AL 100014722



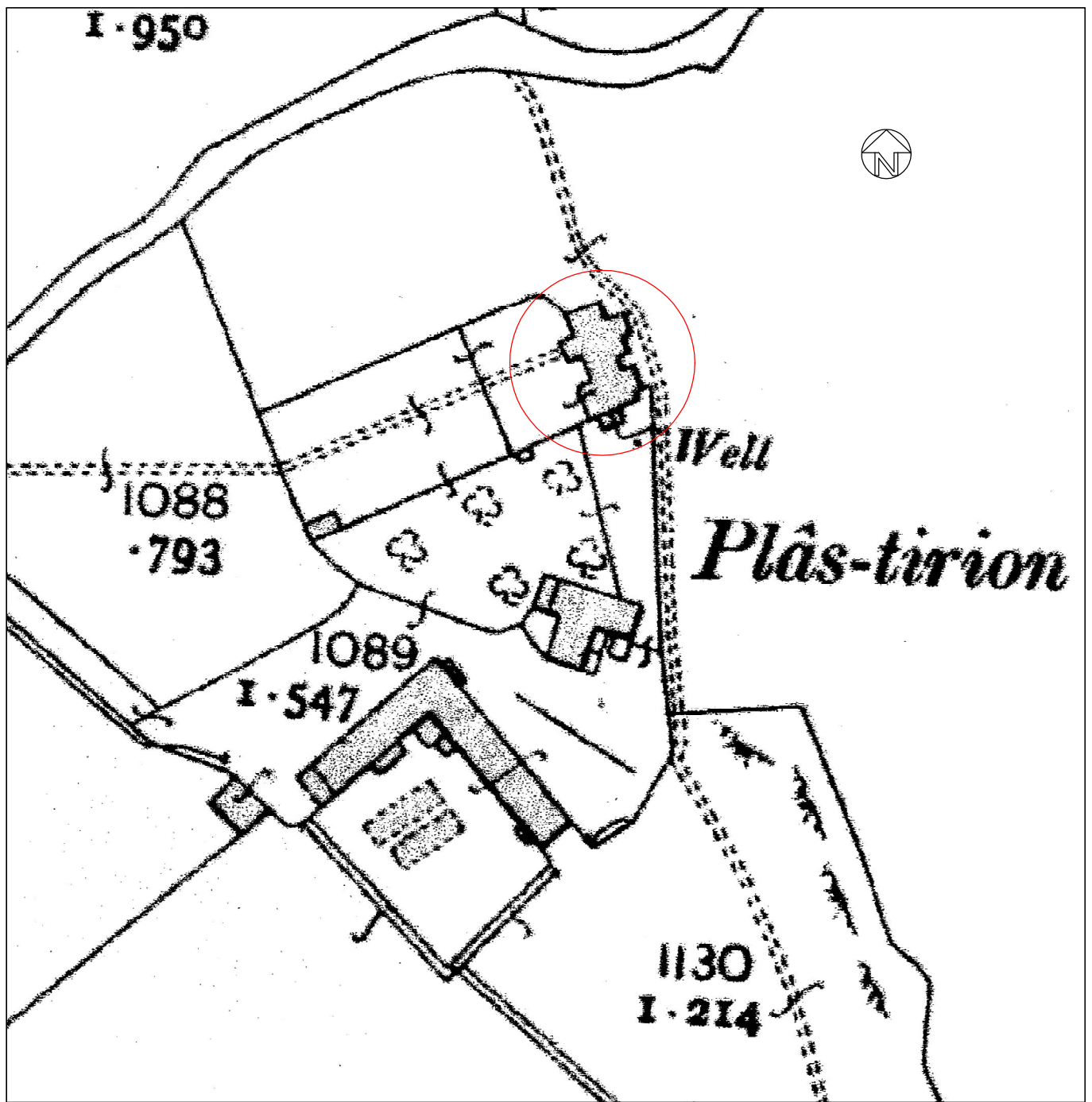

Figure 2: Extract from the Ordnance Survey 1913 Map  
Denbighshire XVI.6  
Re-scaled to 1:1000

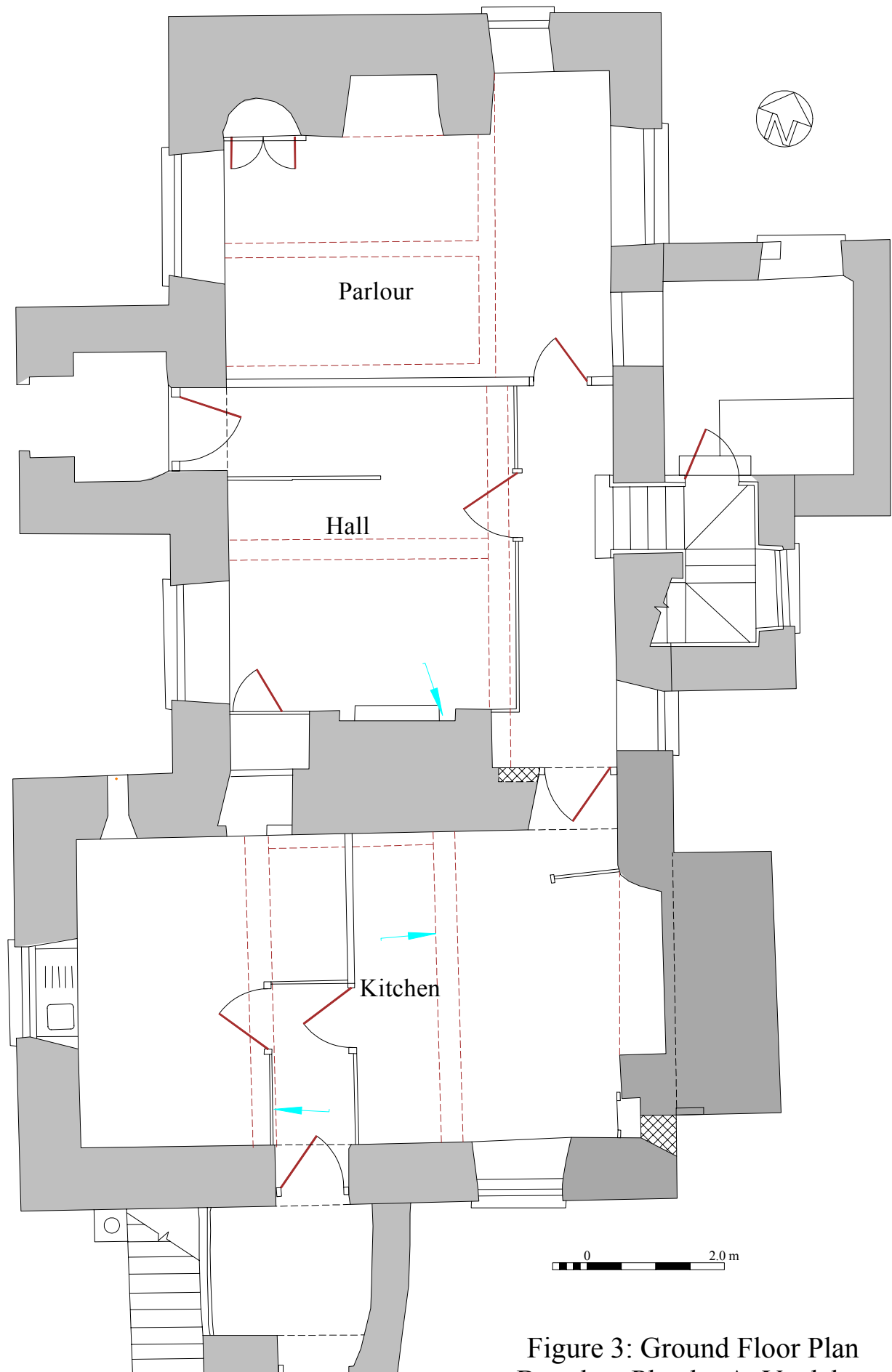

Figure 3: Ground Floor Plan  
 Based on Plan by A. Voelcker  
 Scale 1:80



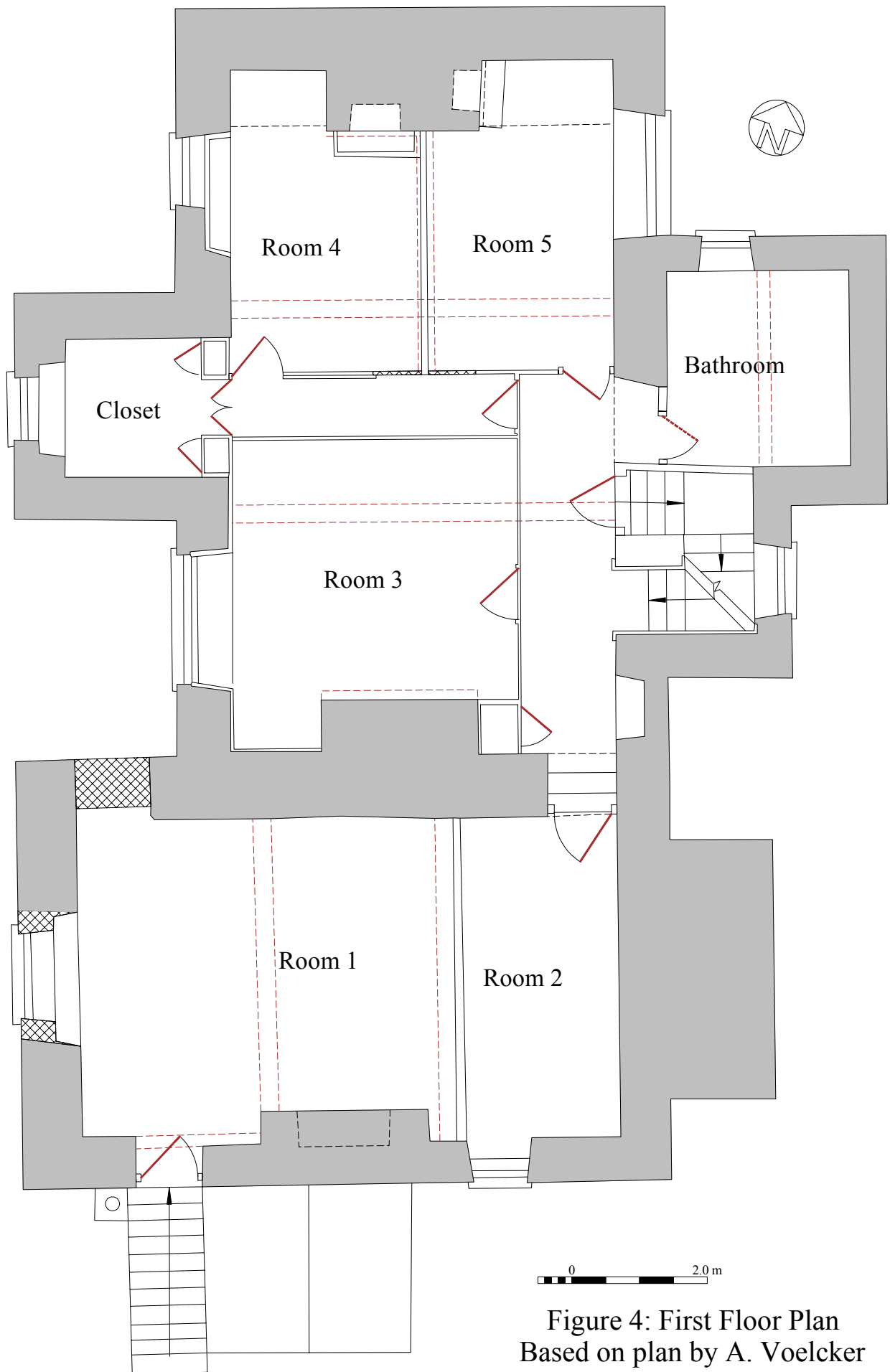

Figure 4: First Floor Plan  
Based on plan by A. Voelcker  
Scale 1:80

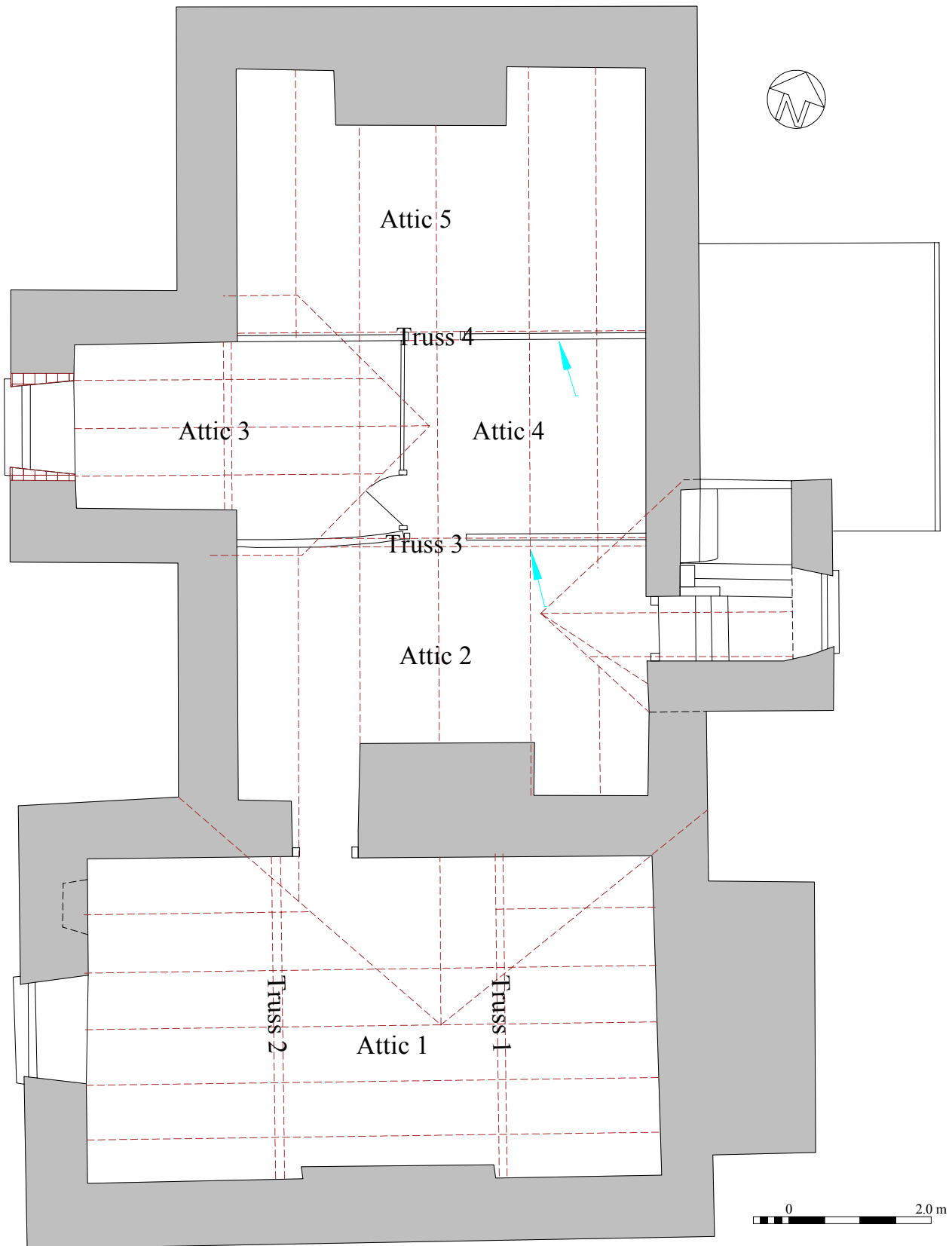

Figure 5: Attic Floor Plan  
 Based on plan by A. Voelcker  
 Scale 1:80

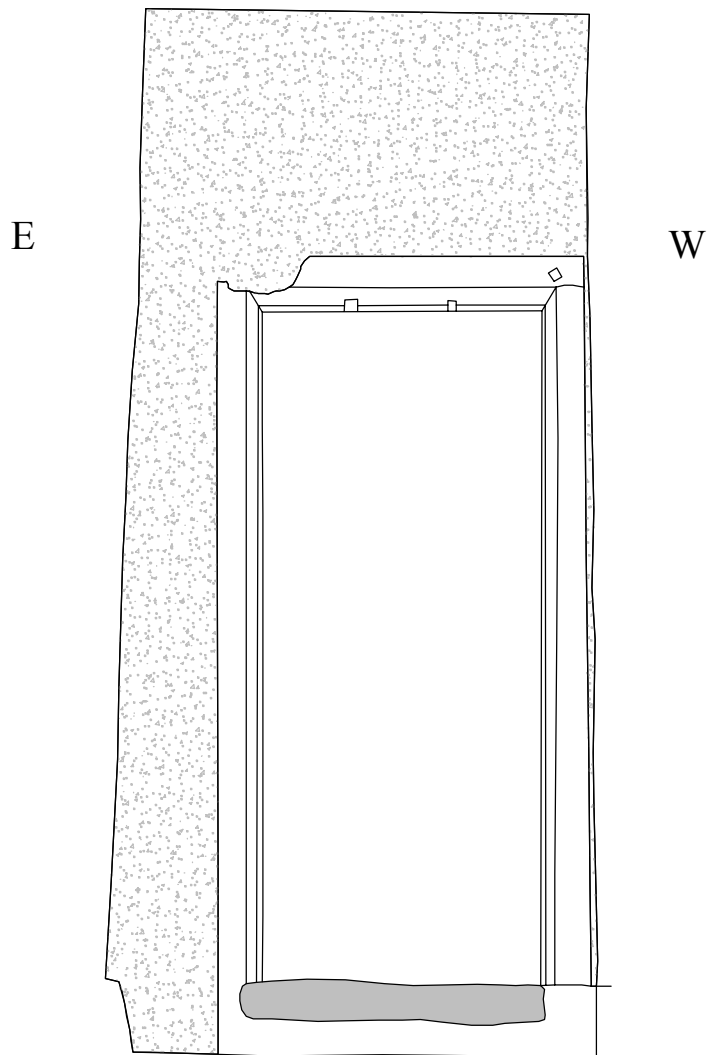
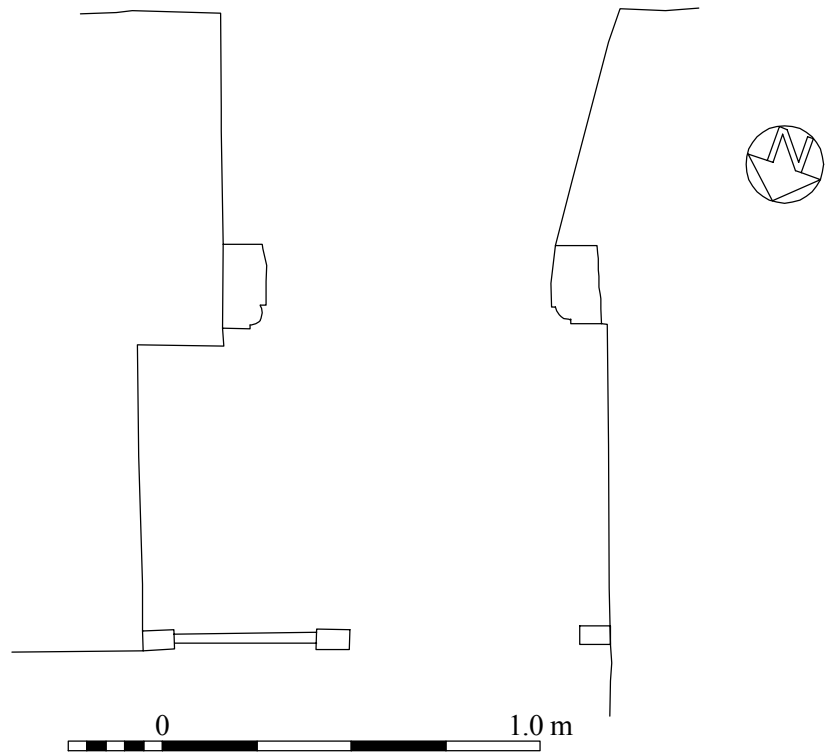
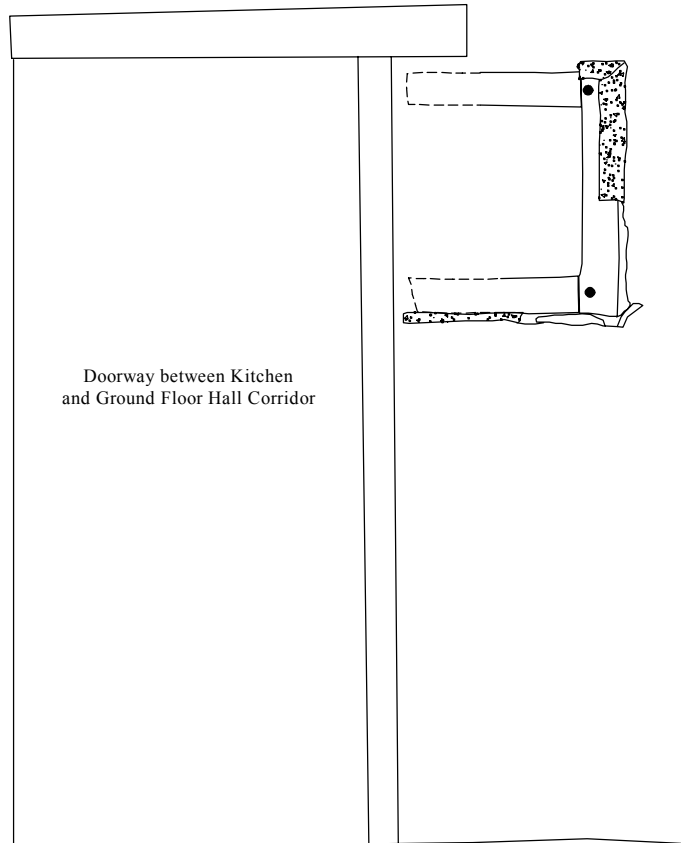

Figure 6: Door between the kitchen and lower hall  
Scale 1:20

E

W



0 500 mm

Figure 7: Blocked Cupboard  
Scale 1:20

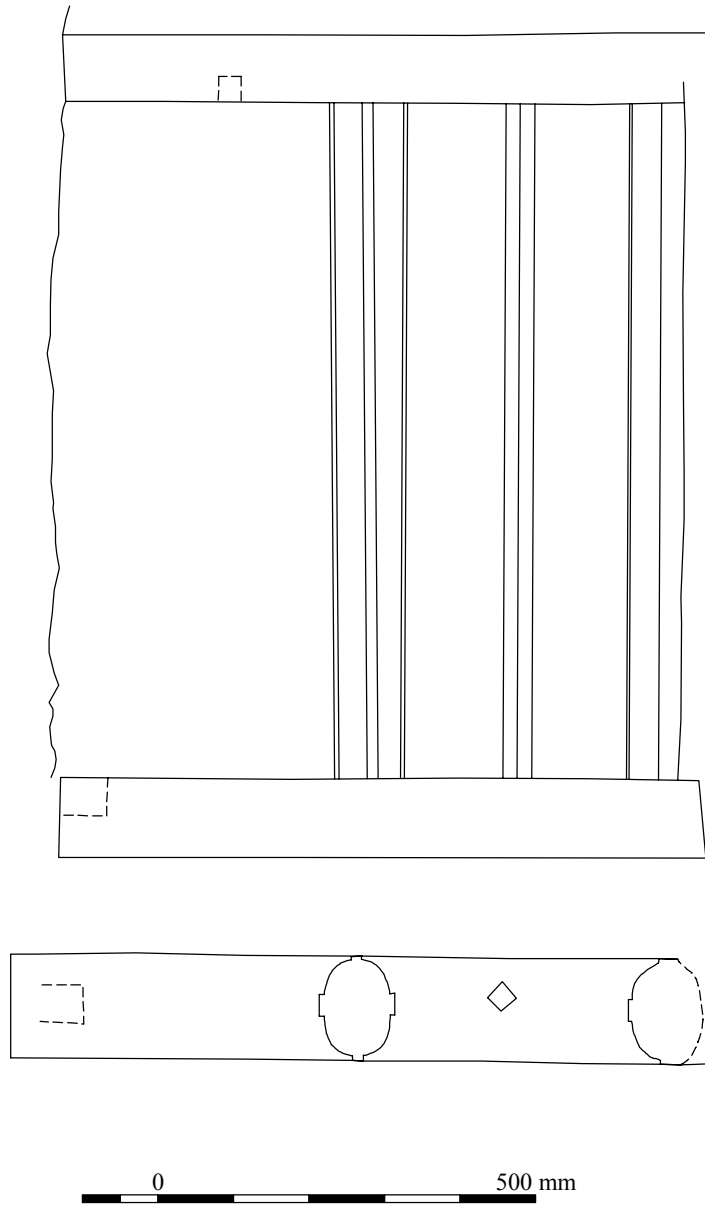
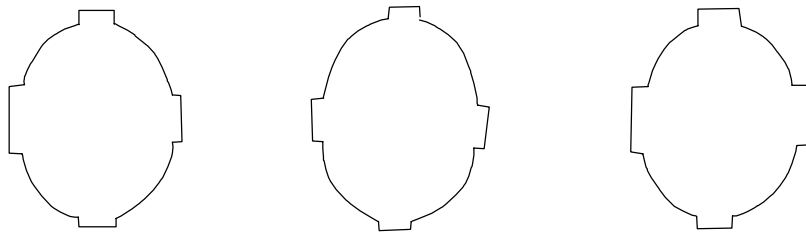

Figure 8: Blocked Window  
Scale 1:10



Blocked Window



Re-used as Stair Supports



Figure 9: Mullions  
Scale 1:5



W

E

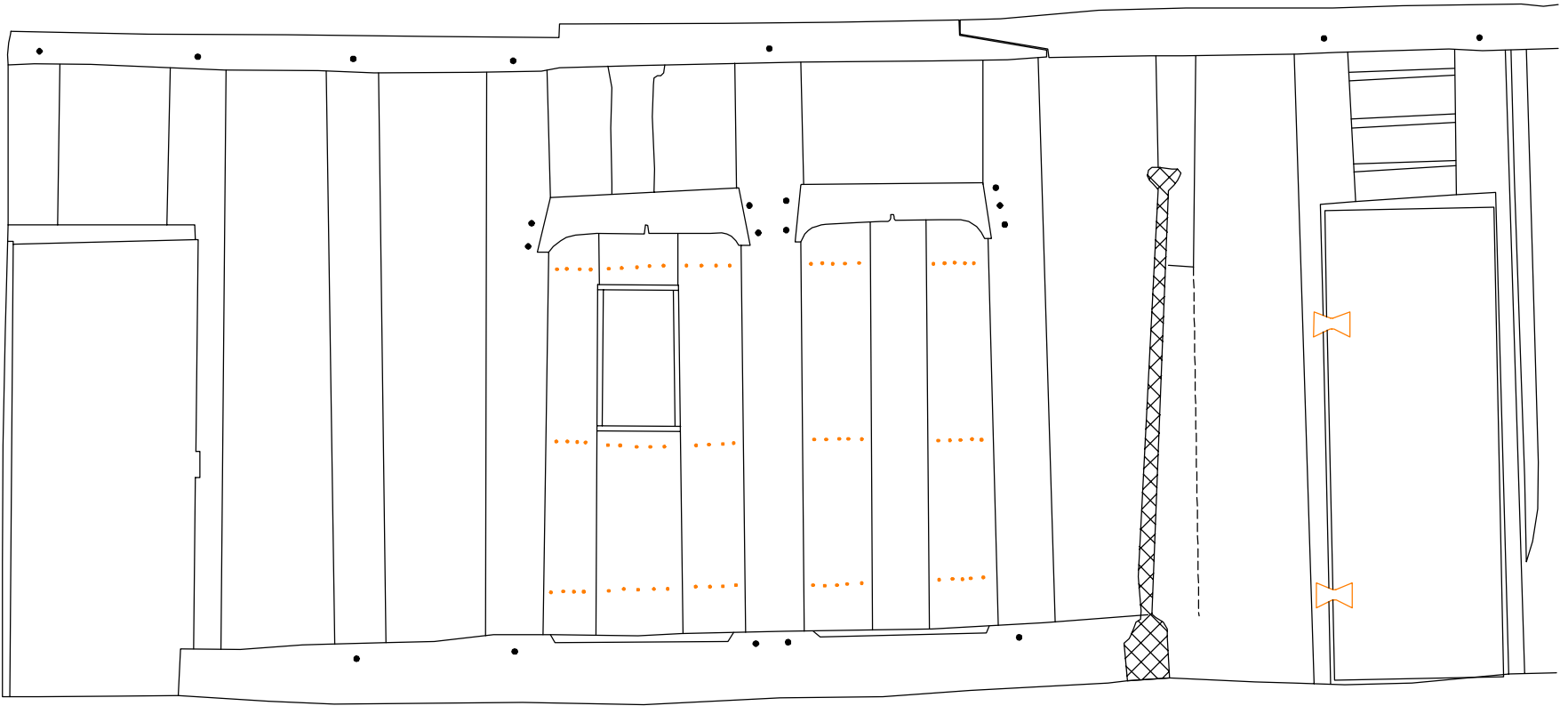
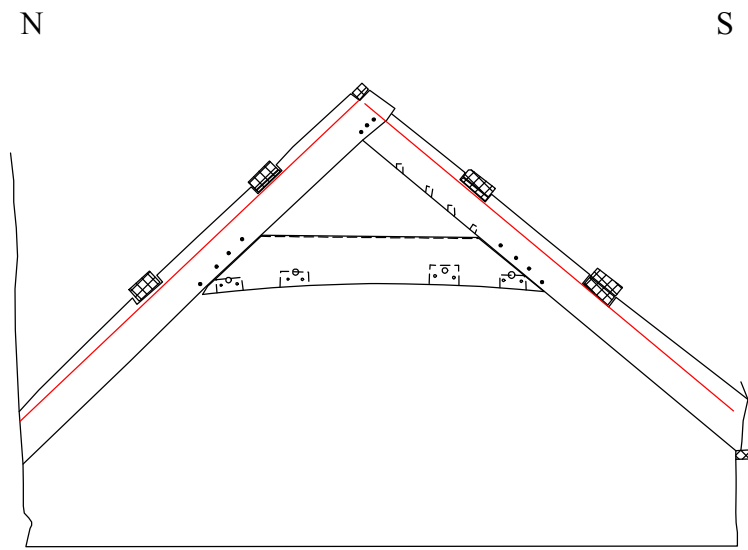
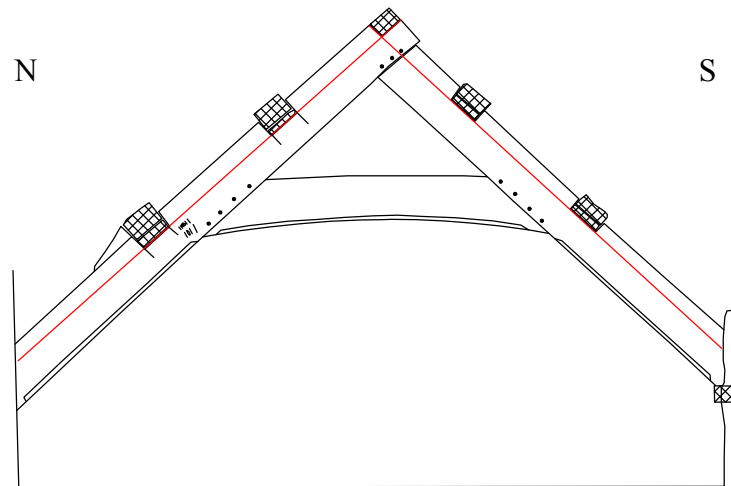

Figure 10: First Floor Partition  
Scale 1:25





Truss 1



Truss 2



Figure 11: Trusses in the Southern Wing  
Scale 1:50

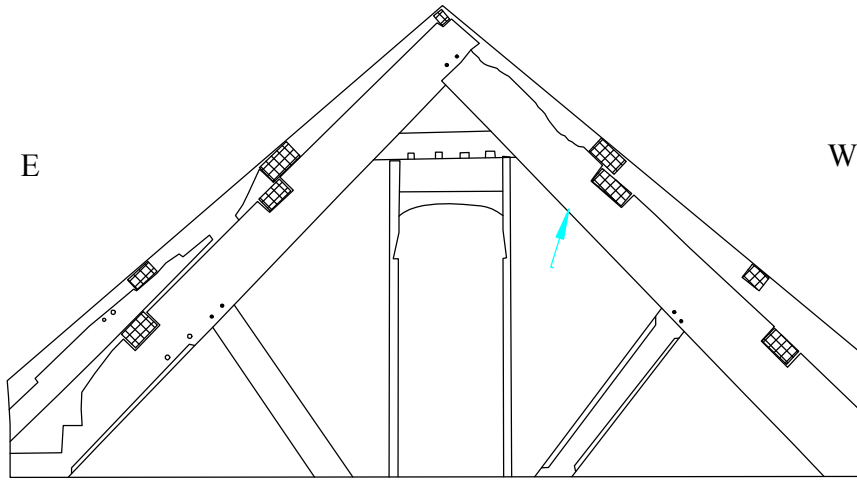

Truss 3

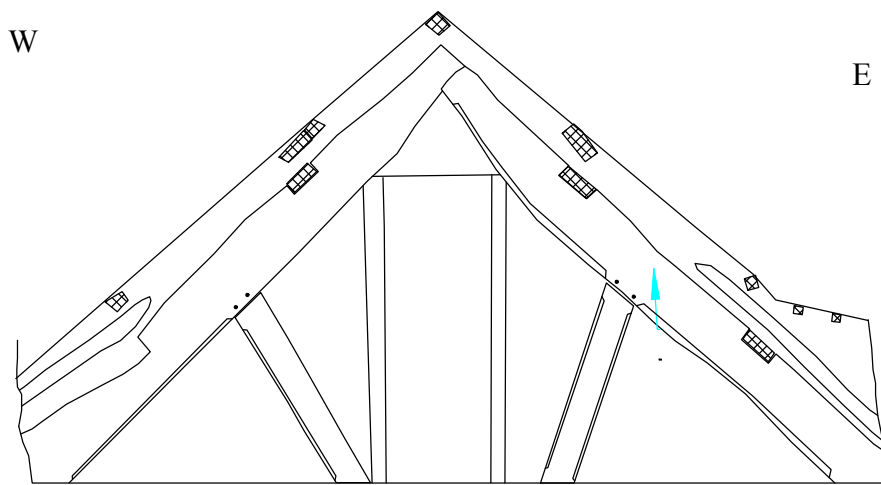

Truss 4



Figure 12: Trusses in the Main Range  
Scale 1:50